



**INSTALLATION, OPERATING AND
MAINTENANCE MANUAL**

for the

Mini Water Heater Electric

Model: MHE-02

(440 VAC Supply x 24 VDC Controls)

Document No: KI-OM-523

Legacy No: 05984-805

(Part No: KI40026AA

(Intentionally Blank)

APPROVAL SHEET

DIVEX					
DOCUMENT NUMBER: KI-OM-523					
LEGACY NUMBER: 05984-805					
DOCUMENT TITLE: Installation, Operating and Maintenance Manual - MHE-02, 440 VAC Supply x 24 VDC Controls					
REV	DATE	BY	CHECK	APP	COMMENTS
0	31/03/2010	R. Carli	N. Maske	R. Faustmann	First Issue
1	11/06/2010	R. Carli	N. Maske	R. Faustmann	Update as per ECN CT 00276
2	26/10/2012	V. Garzon	N. Maske	M. Stevens	Update as per ECN 15089
3					
4					
5					
6					
7					
ORIGINAL ISSUE DATE:			31 March 2010		
ORIGINAL DOCUMENT BY:			Roy Carli		
CHECKED BY:			Nicholas Maske		
APPROVED BY:			Rainer Faustmann		

(Intentionally Blank)

TABLE OF CONTENTS

II	Data Sheet	v
III	Disclaimer	vii
IV	Confidential Information	ix
V	Warranty	xi
VI	List of Tables and Figures	xiii
CHAPTER 1 - GENERAL DESCRIPTION		1
1.1	Introduction	1
1.1.1	Basic Description	1
1.2	Specifications	1
1.3	Theory of Operation	2
1.3.1	Basic Control	2
1.3.2	Fluid System	3
1.3.3	Electrical System Overview	5
1.3.4	Electrical System Detail (Control Logic and Component Identification)	5
1.3.5	Heater System and Heater Selection	6
1.3.6	Control System	7
CHAPTER 2 - INITIAL SET UP		11
2.1	Installation	11
2.1.1	General Mounting and Unit Placement	11
2.1.2	Fluid Connections	11
2.1.3	Electrical Installation	12
2.2	Initial System Check	12
2.2.1	Fluid System Priming Procedure	12
2.2.2	Start Up and Function Check	13
CHAPTER 3 - OPERATION		17
3.1	General	17
3.1.1	Operator Controls	20
3.1.2	Operating Start-Up Procedure	21
3.1.3	Shutdown Procedure	22

CHAPTER 4 - MAINTENANCE	23
4.1 Routine Maintenance	23
4.1.1 Periodic Maintenance	23
4.2 Pump Maintenance	24
4.2.1 Helpful Information	24
4.2.2 Pump Specifications	25
CHAPTER 5 - TROUBLESHOOTING	27
5.1 Pump Specific Fault Diagnosis and Maintenance	27
5.2 General Troubleshooting Chart	29
APPENDIX A - PART IDENTIFICATION	35
APPENDIX B - RECOMMENDED SPARE PARTS LIST & ACQUISITION FORM	39
B.1 Recommended Spare Parts List - (Spares Kit - KI40026AA-KIT)	39
B.2 Recommended Spare Parts – (Not in Spares Kit KI040026AA - KIT)	41
APPENDIX C - SPARES ACQUISITION SHEET	43
APPENDIX D - WIRING DIAGRAMS	45
APPENDIX E - PIPING AND FLOW SCHEMATIC	46
APPENDIX F - RKC CB100 DIGITAL CONTROLLER MANUAL	47
APPENDIX G - BELIMO CONTROL VALVE MANUAL	48
APPENDIX H - WATER PRESSURE REDUCING VALVE	49
APPENDIX I - CAT TRIPLEX PUMP - MANUAL - MODEL 1050	50
APPENDIX J - PULSATION DAMPENER	51
APPENDIX K - PRESSURE REGULATOR	52
APPENDIX L - FLOAT SWITCH	53

II. DATA SHEET

**INSTRUCTION & MAINTENANCE
MANUAL NO:**

KI-OM-523

FILENAME AND PATH:

.....

.....

EQUIPMENT TYPE:

Mini Water Heater Electric - MHE-02
(440V x 24V)

.....

EQUIPMENT SERIAL NO:

.....

CUSTOMER:

.....

VESSEL / LOCATION: (IF KNOWN)

.....

DATE OF ISSUE:

.....

IMPORTANT

Please quote the above information when contacting Divex regarding operational information or spare parts.

(Intentionally Blank)

III. DISCLAIMER

Whilst every effort has been made to ensure the accuracy of the information provided in this document, Divex makes no guarantees therefore.

Misuse of the equipment described in this manual could result in injury. It is the responsibility of the user to ensure that the equipment is used and maintained correctly and in accordance with the instructions provided in this manual in order to ensure safety of life and to prevent injury.

(Intentionally Blank)

IV. CONFIDENTIAL INFORMATION

This document is confidential and is the property of Divex. It may not be distributed to persons or organizations other than the intended recipient without the prior written consent of the owner.

(Intentionally Blank)

V. WARRANTY

Divex Ltd warrants that its **Mini Water Heater Electric (Type MHE-02)**, conforms to the current product specification at the date of delivery and that the product will be free of patent defects in materials or workmanship for a period of twelve months from the date of delivery or for the first 3,000 operating hours, whichever occurs first.

Any component or sub-system which is established by Divex to be patently defective will, at Divex's option, be repaired or replaced on condition that such defective equipment is returned to Divex's manufacturing facility in Cape Town, South Africa, freight pre-paid. On completion of any repair or replacement, the equipment will be returned to the customer FOB Cape Town, South Africa. By agreement and upon prepayment by the customer of any transportation, on-site accommodation and subsistence expenses, Divex may dispatch personnel to perform on-site repairs.

The product specification and warranty terms are subject to alteration without prior notice and do not form part of any contract made between Divex and its customer.

This equipment should only be operated by suitably qualified persons conversant with the operation and maintenance of diver hot water systems. Before operating the equipment, the user must be fully acquainted with the instructions contained in this manual, as well as the individual component manufacturer's operating and maintenance information provided in the Appendixes.

Only genuine manufacturer's spare parts may be used in this Divex product. Use of other manufacturer's parts may cause degradation of performance or failure and will invalidate the warranty.

The following information is required by Divex when ordering spare parts:

- Customer's / owner's name
- Equipment serial number
- Spare part type / description
- Part number

(Intentionally Blank)

VI. LIST OF TABLES AND FIGURES

Fig 1.1	MHE-02 Fluid Connections	4
Fig 1.2	Control Panel Layout	7
Fig 2.1	Controller Display	15
Fig 3.1	Graph of Temperature Loss vs. Umbilical Length	18
Fig 3.2	General Arrangement	20
Fig A.1	MHE-02 General Arrangement - Isometric View	35
Fig A.2	MHE-02 General Arrangement - Side View	36
Fig A.3	MHE-02 General Arrangement – Front View	38
Table 1.1	Heater Component Identification	6
Table 1.2	Control component identification	10
Table 3.1	Heater Selection Table for Required Temperature Rise 19	

(Intentionally Blank)

CHAPTER 1 GENERAL DESCRIPTION

1.1 INTRODUCTION

The Divex Electric Powered Mini Water Heating Module, (MHE-02), has been designed for use in professional diving systems. The system will heat sea water and control the heated sea water within a temperature rise range of 0 to 42°C (0 to 74°F). The system incorporates a positive displacement pump, electric heaters and all electrical controls necessary to provide a complete water heating system for deep diving.

1.1.1 BASIC DESCRIPTION

The MHE-02 assembly includes a motor, pump, heater tank, pipework and a control panel. These components are mounted into a robust stainless steel frame. The system requires a constant supply of sea water and runs from a 440-480V, 3-phase, 60 Hz power supply. The output is heated sea water at pressures up to 68 bar and 30 litres/min.

1.2 SPECIFICATIONS

Shipping Weight	385 kg
Dry Weight	315 kg
Power Requirements	440 VAC, 3-phase, 60 Hz, 94.5 kW, 130 A
Input Fluid	Fresh Water or Sea Water
Input Pressure	3.4 to 10 bar
Input Flow Rate	30 litres / min minimum
Output Pressure	Up to 68 bar
Output Flow	30 litres / min
Temperature Rise Control Range	0 to 42°C (0 to 74°F)
Temperature Control	± 1°C (± 2°F)

1.3 THEORY OF OPERATION

1.3.1 BASIC CONTROL

The temperature control system of the MHE-02 has been designed to be simple and effective. The unit heats water in the heater tank using three banks of heater elements. These heater banks are controlled with three switches, mounted on the electrical enclosure. The banks of heaters are configured to deliver a variety of heating capacities depending on the combination of banks selected. When all three heater circuits are on, the total rated heater output is 94.5 kW. The appropriate heater circuits must be selected manually according to the relative temperature rise required. A schedule is attached to the front of the control panel door indicating the heater banks to be used for the required temperature rise.

Example: Heater bank selection for required temperature rise through the MHE

T_d	-	Required outlet water temperature, at diver	=	38°C
$T_{\Delta h}$	-	Temperature drop (Hose from deck to diver	=	8°C
T_i	-	MHE Inlet water temperature is	=	10°C
T_o	-	MHE Required outlet water temperature	=	$(T_d + T_{\Delta h})$
	-		=	$(38 + 8)^\circ\text{C}$
	-		=	46°C
ΔT	-	Required temperature rise through the MHE	=	$(T_o - T_i)$
	-		=	$(46 - 10)^\circ\text{C}$
	-		=	36°C (Use heater banks 1, 2 and 3)

The above example shows that if a bottom temperature of 38°C is required with a temperature drop through the hose to the diver of 8°C and an inlet water temperature of 10°C. The temperature required at outlet from the MHE would be 46°C. The required temperature rise through the unit would be 36°C. The heater selection table shown in **Table 3.1** indicates that heater banks 1, 2 and 3 should be used for the required temperature rise through the unit.

Once the correct configuration of heater banks has been selected and the required setpoint entered into the temperature controller, the controller will regulate the temperature of the outlet by adjusting the flow rate of water through the heater tank. This is achieved by controlling the electric actuator on the bypass valve. The valve is connected in such a way that it will dump a proportion of the heated water overboard thereby increasing the flow rate through the heater tank. A higher flow rate through the heater reduces effective temperature rise and maintains the desired set point temperature at the outlet. The temperature controller monitors the temperature at the fluid outlet manifold using a PT100 temperature sensor and adjusts the control valve position to achieve the set point temperature.

IMPORTANT

The calculated required temperature rise may be indicated on the heater bank selection schedule as a maximum for one configuration and a minimum on the subsequent selection of heater banks. In this case practical application will dictate which configuration should be used. The higher capacity configuration is usually used to allow for better control.

If the bypass dump valve remains fully open during normal operation, indicating heating over-capacity then the lower kW heater configuration should be used to improve control and unit performance.

If the bypass valve remains fully closed during normal operation, indicating heating under-capacity or a possible heater bank fault then a higher kW configuration should be used to improve control.

1.3.2 FLUID SYSTEM

The MHE-02 may function with either salt water or fresh water as the heating medium. The unit is provided with two inlets for fluid, one for fresh water and one for sea water. The fresh water line is typically used for flushing the system after use. The freshwater line is fitted with a check valve to prevent salt water contamination of the fresh water supply. The unit uses small inexpensive immersion heater elements mounted in the flange plate of the stainless steel heater tank to heat the fluid. The flow rate of the fluid through the heating tank is governed by the action of the bypass valve.

IMPORTANT

Fluid supply to the unit by the vessel must be maintained above 30 litres/min at 3 bar for correct operation.

The flow rate of fluid from the heater tank to the divers is determined by the motor speed and the ratio of the pulley set used to couple the motor to the pump. The pump is a positive displacement pump and is designed and supplied with a pulley arrangement to provide a flow rate of **30 litres/min**.

The fluid to be heated enters the unit at the assigned inlet and flows through a manifold and a quarter-turn hand valve. The manifold is equipped with analogue temperature and pressure gauges to provide operator feedback on the fluid supply. The fluid is then piped to two separate inlet filters. The two filters may be isolated using hand valves on the inlet and outlet of each filter. Only one filter should be used under normal operation with the other on standby and ready to be put into operation. These filters clean input water of particulate matter down to 50µm in order to protect the piston pump and umbilical coupling from being damaged and prevent clogging of the heating water tubes in the diver suits. The inlet filters are each fitted with pressure gauges in order to monitor pressure drop across the filter and indicate the condition of the filter cartridge. A pressure regulating valve fitted after the filter

outlet ensures that fluid is supplied from filters to heater tank at a consistent and safe pressure.

The fluid flows through the heater tank which houses immersion heater elements where fluid is heated. A float switch housed in the level control tank mounted on top of the heater tank is used to ensure the heater elements and pump are not run without sufficient supply. If the level in the tank drops the level switch shuts down the system. From the level control tank, the fluid is distributed to the temperature control valve, manual temperature control valve and pump. The manual control valve controls the process in the same way as the automatic control valve and is provided to control outlet temperature if automatic control is inactive. The pump supply is directly coupled to the level control tank.

The pump is a positive displacement pump and provides consistent supply flow rate. An accumulator is fitted to reduce the effect of pulsation caused by the pump. The fluid from the pump flows through a pressure relief valve which may be set between 7-70 bar and is sufficiently sized to allow full flow bypass if a downstream blockage occurs. During normal operation, the hot water flows through a flexible reinforced hose to the outlet via the outlet manifold. The outlet manifold is fitted with both pressure and temperature gauges to provide operator feedback.

A full flow diagram and system drawings are provided in the Appendix.

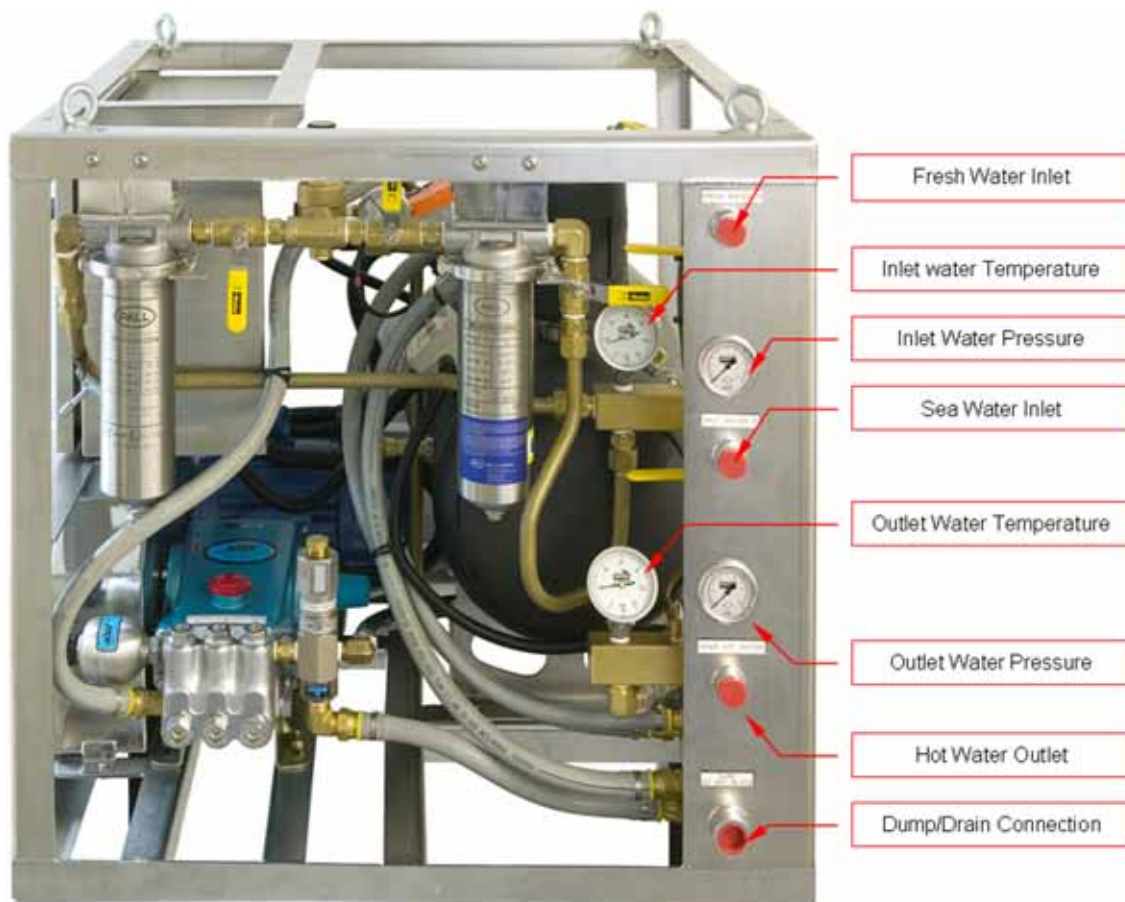



Fig 1.1 MHE-02 Fluid Connections

1.3.3 ELECTRICAL SYSTEM OVERVIEW

The MHE-02 electrical system is comprised of a 440 VAC power circuit and a 24 VDC control circuit. The power circuit is the electrical supply for the heaters, pump motor and DC power supply unit. The control circuit provides power supply to all control, indication and safety circuits.

	DANGER
	<p>HIGH VOLTAGE – HIGH CURRENT</p> <p>This is a high voltage / high current system and only trained, competent personnel should attend to installation, service and maintenance requirements. All relevant safety procedures must be followed.</p>

1.3.4 ELECTRICAL SYSTEM DETAIL (CONTROL LOGIC AND COMPONENT IDENTIFICATION)

The main isolator located in the electrical panel is used to switch the main power of the unit on and off. As detailed in the heater power circuit in **APPENDIX D**, power is then distributed to the heater and pump circuit breakers and the DC power supply unit. The control system wiring diagram is detailed in **APPENDIX D**.

1.3.5 HEATER SYSTEM AND HEATER SELECTION

The heaters are arranged into heater banks comprised of groups of heater elements. Each heater bank is controlled by a switch mounted in the control panel. The switch supplies 24V to the coil of the contactor/s of the relevant bank. The following table shows the control structure of the heater banks and the composition of the heater groups.

Bank No.	Switch No.	Element Grouping No.	Circuit Breaker ID	Contractor ID	Element Grouping kW	Element Grouping Composition
1	1	Heater 1.1	MCB2	C2	13.5 kW	3 x 4.5 kW Elements
2	2	Heater 2.1	MCB3	C3	27.0 kW	3 x 4.5 kW Elements and 3 x 4.5 kW Elements
		Heater 2.2				
3	3	Heater 3.1	MCB4	C4	27.0 kW	3 x 4.5 kW Elements and 3 x 4.5 kW Elements
		Heater 3.2				
		Heater 3.3 Heater 3.4	MCB5	C5	27.0 kW	3 x 4.5 kW Elements and 3 x 4.5 kW Elements
NOTE: Bank 3 provides a total of 54 kW of heating.						

Table 1.1 Heater Component Identification

The grouping of the heater elements into banks allows the sequential switching of the banks, reducing the instantaneous load on the supply. As heater banks have separate control circuits and protection, the failure of any single bank of heaters will not effect the operation of the other banks.

1.3.6 CONTROL SYSTEM

The 24 VDC control circuit is used to control the contactors, relays, timer and the safety circuits in the system. The contactors, controlled by switches mounted in the control panel door, switch the high voltage to the heaters and the pump.

The temperature of the output fluid is regulated by dumping excess capacity thereby increasing the flow rate of fluid through the heater tank and lowering the output temperature of the fluid outlet. The amount of fluid dumped is controlled by an electronic controller that operates the actuator on the control valve. The amount to which the valve is opened is determined by the controller based on feedback received from the PT100 temperature probe mounted into the outlet manifold.

Several safety interlocks are incorporated into the control system which provide protection against low fluid level in the heater tank, over-temperature and motor overload trip. The control circuit also includes indication via illuminated rotary switches and the controller display for operator feedback. **Fig 1.2** below shows the control panel layout and part identification.

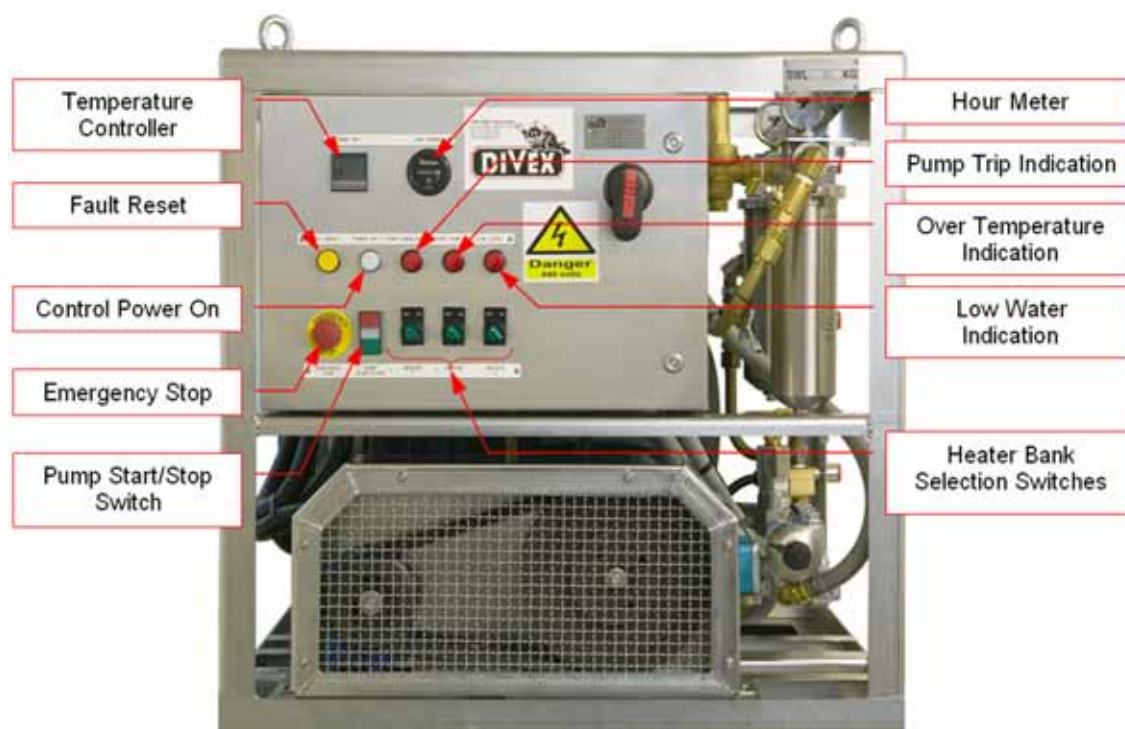

Fig 1.2 Control Panel Layout

The following table identifies the major control components, and outlines their function within the control circuit.

COMPONENT	COMPONENT ID	FUNCTION DESCRIPTION
Contactors 1	C1	Pump contactor coil
Contactors 2-5	C2-C5	Heater contactor coils
Hour Meter	H1	The hour meter records the running hours of the pump and is wired through the auxiliary contact on the pump contactor C1/1 .
Run Light (Green) Motor On	L1	LED indicating the pump motor contactor is operational and power is supplied to heater switches. Wired to the motor start switch S2NO and the auxiliary C1/1 of the motor contactor C1 .
Run Light (Green) Heater Bank On	L2-L4	LED indication of heater bank power on. (Supply to heater contactor coil.)
Run Light (White) Control Power On	L5	LED indicating 24 VDC power to control circuit.
Fault Light (Red) Pump Trip/ Overload	L6	LED indicating pump fault/overload trip. Wired to normally open contact of overload O/L1 .
Fault Light (Red) Over Temperature	L7	LED indication of system over-temperature. Wired to the normally closed contact R1/2 of relay R1 .
Fault Light (Red) Low Level	L8	LED indication of low water level. This fault is wired to the normally closed contact R2/2 of the low level relay R2 .
Fuse Transformer Supply	F1- F2	Fuses for short circuit protection or overload of the supply to the power supply unit.
Fuse Control Circuit	F3	Fuse for short circuit protection or overload of the supply from the power supply unit to the control circuit.

COMPONENT	COMPONENT ID	FUNCTION DESCRIPTION
Pump Overload	O/L1	This overload trips if the pump draws a current of over 12 Amps. The normally open contact of the overload supplies the pump run indication. The normally closed contact of the overload is used in the safety circuit.
Fault Relay Over Temperature	R1	Relay de-energizes during fault when the contacts R3/1 of the controller over temperature relay R3 or the thermostat contacts are open. The over temperature relay is interlocked with its normally open R1/3 contact. This circuit requires fault reset.
Fault Relay Low Water Level	R2	<p>The fault relay de-energizes during fault when the normally closed contact T1/1 on the float level de-bounce timer is open. The timer is triggered by the normally closed contact of the float switch. This arrangement is used to reduce nuisance faults attributed to level switch vibration or bouncing.</p> <p>The normally open contact R2/1 is used in the safety circuit to remove power from the pump and heaters during fault.</p> <p>The normally closed contact R2/2 is used to supply power to low level indication LED.</p> <p>The normally open contact R2/3 is used to interlock the low level relay.</p> <p>To reset the fault circuit fault reset must be pushed.</p>
Fault Relay (controller) Over Temperature	R3	This relay is activated by the controller. The normally closed contact R3/1 of the relay is used in the over-temperature relay R1 circuit.
Switch Push Button Motor Start	S2NO	This normally open contact supplies power to the pump contactor C1 .
Switch Push Button Motor Stop	S2NC	This de-energizes the motor control circuit and heater switch supply. Controller and safety circuits will remain energized.

COMPONENT	COMPONENT ID	FUNCTION DESCRIPTION
Switch Rotary Heater Selection	S3, S4 & S5	The two position heater ON/OFF switches control the switching of the power to the coils of the respective heater contactors C1-C5 . (See Table 3.1).
Switch Mushroom Emergency Stop	S1	This switch contact de-energizes the motor and heater control circuits. The pump and heaters are switched off. The controller and safety circuits remain energized. This switch is latched with a twist release.
Switch Fault Reset	S6	The fault reset switch unlatches the over-temperature and low level fault interlock circuits and allows normal function.
Switch Float	FS	The float switch mounted in the level control tank is used to prevent the system function if the water level in the heater tank is too low. The contact is used to activate the de-bounce timer.
Timer	T1	The de-bounce timer is used to eliminate nuisance faults due to the bouncing of the float switch in the level control tank. The normally closed contact T1 is used to de-energize the low level relay R2 . Timer is factory set to 2 seconds.

Table 1.2 Control component identification

CHAPTER 2 INITIAL SET UP

2.1 INSTALLATION

2.1.1 GENERAL MOUNTING AND UNIT PLACEMENT

The Electric Powered Hot Water Heating Module, MHE-02, is built into a robust stainless steel frame, which ensures that all the required systems and controls can be securely mounted inside a single convenient assembly. The unit should be securely mounted in an area that is protected from environmental elements. The unit mounting should allow free access on three sides of at least 0.5 to 1 m for service and maintenance.

2.1.2 FLUID CONNECTIONS

The MHE-02 requires both salt and fresh water supply with a minimum flow rate of 30 lit/min at 3 bar.

NOTE

This is the minimum required for Cat pump supply, up to approximately another 30 ltr/min may be required for adequate temperature control).

The recommended minimum tubing size is 3/4". The fluid input connections are made by attaching the pipes to the relative 3/4" NPT penetrator of the unit. Flexible hoses with suitable connections may also be used to facilitate the integration of the unit into an installation. The maximum acceptable water inlet pressure is 10 bar.

The MHE-02 Hot Water outlet is a 3/4" NPT stainless steel penetrator. This may supply a valve manifold or a single pipe connection depending on the installation requirements. The plumbing used should be capable of withstanding the maximum working pressure of 68 bar. All valves, fittings, tubing and manifolds connected to the hot water system must be capable of working at this pressure. If the system is not required to deliver this pressure, the relief valve may be set to a lower setting, and all the attached hot water delivery plumbing may be selected to suit this reduced pressure.

A 1" pipe must be connected to the overboard dump fitting allowing unrestricted flow of bypass or dumped fluid from the unit.

	DANGER
	<p>DUMP LINE BLOCKAGE</p> <p>To ensure safe operation of the unit the dump line must always be <u>open</u>. Shutting off the dump line will compromise the system safety and could lead to severe injury.</p>

	CAUTION
	DUMP LINE RESTRICTION To ensure correct machine operation, the dump line should never restrict flow of dumped water.

The 1" dump pipe may be connected to any water dump system that has minimal back pressure. The volume of water being dumped during manual and/or automatic control may vary however in the event of complete restriction of the hot water outlet line and the resultant rise of the outlet pressure above the relief pressure the full flow will have to be dumped via the relief valve.

2.1.3 ELECTRICAL INSTALLATION

The electrical requirements of the system are **460 VAC ±20 V @ 60 Hz** with a maximum current of **140A**. The unit is fitted with a 160A rated isolator and power supply cable must be suitably rated armoured cable, to an approved marine standard specification.

The mains power input to the system should be fitted to the bottom right hand side of the stainless steel electrical enclosure. The mains power cable should be installed through a suitable gland and correctly grounded to the armour. Mains cable connections to the isolator terminals must be tightened and checked.

	DANGER
	POWER CONNECTION Ensure that the power supply is turned off before connecting any wiring

After the mains power cable is installed, check for acceptable grounding and continuity. Do not start up the system until these tests have been conducted.

2.2 INITIAL SYSTEM CHECK

2.2.1 FLUID SYSTEM PRIMING PROCEDURE

After the electrical and pipe work installations have been completed, purge the piping system of air in order for the pumps to function properly and for the electric heater elements to be fully immersed.

	CAUTION
	<p>LOW WATER LEVEL OPERATION</p> <p>The equipment may be severely damaged if heaters are supplied with power when there is no water in the system.</p>

Use the following procedure to correctly prime the system:

1. Open the salt or fresh water input valve slightly to allow water to flow into the system. Water supply should be at sufficient pressure (± 3 bar).
2. Check that all the ball valves on the filters are open.
3. With the vent valve on top of the level control tank open, leave the water supply on until water flows out of the vent tube.
4. Close the vent valve and wait for water to flow through the pump and out of the HP water outlet fitting.
5. Allow the water to run for 5 to 10 minutes in this mode.
6. Confirm that the heater tank is full by opening the tank vent valve to purge any residual bubbles in the heater tank.
7. To complete priming shut the vent valve and supply valve(s).

2.2.2 START UP AND FUNCTION CHECK

After installation is complete the MHE-02 must be thoroughly checked prior to being put into service. The following procedure outlines the steps used in conducting a comprehensive start-up and functional check.

1. **Power Supply** - Turn on the mains power to the unit. Input power must be within specification (3-phase, 440 – 480 V, 60 Hz) and supply must be adequately rated.

	CAUTION
	<p>FAULT INDICATION</p> <p>The system will be prevented from being started if faults are indicated. Press the fault reset button to clear any fault indication.</p> <p>If fault indication is not reset or the fault recurs refer to troubleshooting for corrective action.</p>

2. **Pump Oil Level** - Check the oil level in the pump crankcase (level with dot on sight glass).
3. **Pump Rotation** - To check the rotational direction of the motor push the start button and then stop button. This will momentarily power the pump motor. Confirm the correct rotation of the pump as indicated by the rotation arrows on the both sides of the pump. Pulley rotation should be clockwise when viewed from the control panel side of the unit. Incorrect rotation may be solved by interchanging any two phases of the supply to the motor.
4. **Controller Setup and check** - To power up the controller ensure that the main isolator and all the circuit breakers are switched on. Check the controller settings before function testing. As shown in **Fig 2.1** the controller display indicates the Measured Value (PV), Set Value (SV) and run indication for the Auto tuning (AT), Output 1 and 2 (OUT1, OUT2) and Alarm 1 and 2 (ALM1, ALM2). The display is used during setting to show parameters and functions.

Changing Set Point - Press the Set key to enter the SV Setting Mode. To change the controller set point, use the <R/S key to select the digit to be changed and the arrow keys to change the digit.

Parameter Setting Mode - Press the Set key for 2 seconds to access the Parameter Setting Mode. Use the Set key to page through the Parameters. The Mode key is used to select a parameter and the arrow keys to change the parameter setting. Use this procedure to check the following parameter settings:

Alarm 1	(AL1)	=	10
Proportional Band	(P)	=	5.6
Integral Time	(I)	=	241
Derivative Time	(D)	=	60

Press Set key and return to Main Display.

NOTE

These are factory settings and should not need to be adjusted. Refer to **APPENDIX F** for a full copy of the controller operator manual.

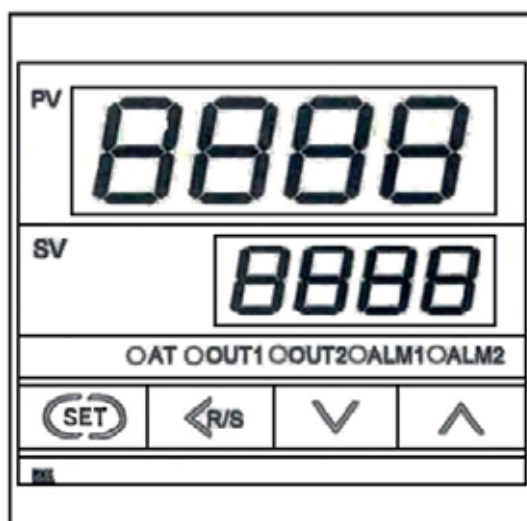



Fig 2.1 Controller Display

5. **Fill Umbilical** – Connect umbilical to HP water outlet port and open the salt water inlet valve. Allow water to flow through the system until it flows out of the umbilical. Salt water or fresh water may be used depending upon which is available.
6. **Pump Motor Start** - Push the pump Start button, the pump will start running and system pressure will rise to balance the pressure drop down the length of umbilical. The flow rate will be approximately 30 lit/min.
7. **Pump Flow Rate** - The pump is a positive displacement type and the flow rate may only be limited by an under-supply of water to the pump. To check flow rate, use an inline flow meter on the outlet or collect the water from the output in a container of known volume and measure the time it takes to fill this know volume.
8. **Heater Bank Selection** - Determine the temperature rise required through the unit to provide the correct temperature of fluid at the user. Use the heater selection table, (See **Table 3.1**), mounted on the panel door to determine which heater banks should be used to achieve calculated temperature rise. Switch on the required heater bank switches sequentially. Refer to trouble shooting if any fault lights illuminate during this operation.
9. **Monitor Performance** - Monitor the unit inlet and outlet temperature and the differential temperature rise. The outlet temperature should rise until the set point is reached. As the outlet temperature approaches the set point the controller begins to govern the process by activating the automatic dump valve. The process should stabilize and accurately maintain the temperature differential provided that the inlet flow rate and temperature is sustained and consistent. The inlet water pressure should be a minimum of 3 bar and should be maintained during dumping of excess hot water.
10. **Filter Check** - Two water filters are provided to clean inlet water. One for operation and the other for stand-by. The pressure drop across each filter should be between 0.5 – 1 bar. Check the pressure drop after running the unit for a 4 to 5 hour settling-in period. The filter will trap all contaminants introduced into the system during installation and

should be regularly checked after set-up. Replace the filter elements (DSA Part No. 04793) when the pressure drop rises above 1.2 bar.

11. **Current Drawn** - Check input current and voltage to make sure acceptable limits are maintained.
12. **Process Control** - When the unit is set-up and operating properly with the correct heater selection and supplies it will deliver water heated to within $\pm 1^{\circ}\text{C}$ of the controller set point. Confirm that the unit controls the process as specified.

	CAUTION
	SYSTEM FLUSHING When the system is not in use it should be thoroughly flushed with fresh water and completely drained according to the Shutdown Procedure detailed in Section 3.1.3.

IMPORTANT
When diving in dirty water it may be necessary to pre-filter the water supply to the mini water heater to 100 micron to ensure satisfactory performance and manageable filter element changeovers.

CHAPTER 3 OPERATION

3.1 GENERAL

The Divex Electric Powered Mini Water Heating Module has been designed to run with the minimum amount of operator input. The temperature controller governs the process based on the set point and feedback from the PT100 probe giving the measured output temperature (PV). The operator is required to input the set point to the controller and switch on the appropriate heater banks to provide the required capacity.

Before running the unit the operator must determine the required heating capacity for the application. The following steps outline the procedure for the determining this capacity.

- Approximate length of umbilical in water (L_U)
- Approximate operating temperature of fluid desired at bottom (T_b)
- Inlet water temperature (T_{in})

Step 1 - Determine total outlet temperature.

Using the graph in **Fig 3.1** to determine the temperature loss along the umbilical hose, select the length of the umbilical hose on the vertical y-axis and move horizontally to the right until the line is intersected then move vertically upward to the horizontal x-axis. The value on the x-axis will yield the approximate temperature loss (T_{loss}) through the specified length of umbilical.

Add the temperature loss through the umbilical to the temperature required at the diver. This will give the total outlet temperature (T_{out}) required. This value must be entered into the controller as the control set point value (SV).

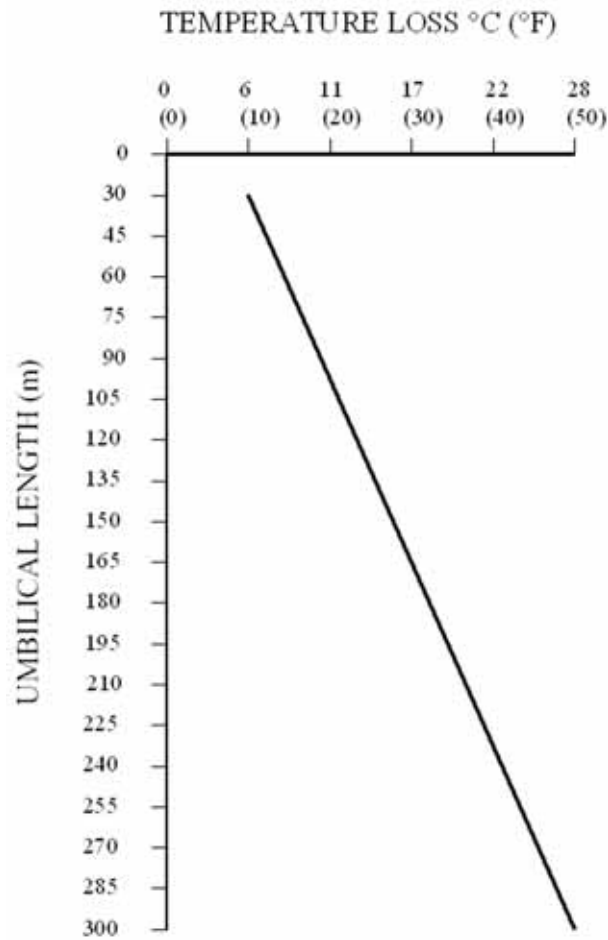

Fig 3.1 Graph of Temperature Loss vs. Umbilical Length

NOTE

The above graph is based on the approximate temperature loss through a ½” Synflex or equivalent, used in conditions with 2-5°C (35-45°F) water temperature.

Step 2 - Determine temperature rise required.

To determine the required temperature rise (T_{rise}) through the unit subtract the inlet temperature (T_{in}) from the required total outlet temperature calculated in Step 1.

Step 3 - Heater bank selection.

After calculating T_{rise} use the table in **Table 3.1** to determine the heater banks to be used. Locate the temperature rise in the left column. Read across to determine which heaters are required to achieve the temperature rise. A dot indicates that a heater bank should be switched on.

380 VOLT TEMP RISE		HEATER ON (●)			
°C	°F	HEATER 1	HEATER 2	HEATER 3	kW
0-5	(0-9)	●			13.5
5-10	(9-18)		●		27.0
10-15	(18-27)	●	●		40.5
15-22	(27-39)			●	54.0
22-29	(39-51)	●		●	67.5
29-35	(51-62)		●	●	81.0
35-42	(62-74)	●	●	●	94.5

Table 3.1 Heater Selection Table for Required Temperature Rise

IMPORTANT

The required temperature rise shown in Table 3.1 indicates the differential between inlet and outlet temperatures that will be achieved for the specified heater bank selection.

Example: Temperature rise calculation

Umbilical Hose Length 105 m

Desired Temperature at Bottom (T_b) 35°C

Inlet Water Temperature (T_{in}) 10°C

From graph 1: T_{loss} for 105 m = 11°C

The Temperature Controller set-point (SV) should be set to the Outlet Temperature (T_{out}).

Where: $T_{out} = T_b + T_{loss} = 35 + 11 = 46°C$

The Temperature rise through the MHE = $T_{rise} = T_{out} - T_{in} = 46 - 10 = 36°C$

As indicated in the selection chart in **Table 3.1** for a 35–42°C temperature rise, heater banks 1, 2 and 3 should be switched on.

The above heater selection will supply the approximate heating capacity required to produce the specified temperature rise through the unit. The controller will accurately control the outlet temperature to achieve the required set point.

IMPORTANT

Table 3.1 is intended only as a general guide and due to variations in installations, operating conditions and working environments it is important to monitor the function of the unit to ensure that the process is correctly controlled. If the control valve is constantly open this indicates over-heating and a lower heater selection may be used. If the control valve is constantly closed this indicates under-heating and a higher heater selection may be used.

3.1.1 OPERATOR CONTROLS

Operator control of the MHE-02 is achieved using the controller keypad to change the set point and switches for heater bank selection. The MHE-02 is also equipped with several analogue gauges displaying fluid temperature and pressure throughout the system. The layout of the operator interface is shown in **Fig 1.2**.

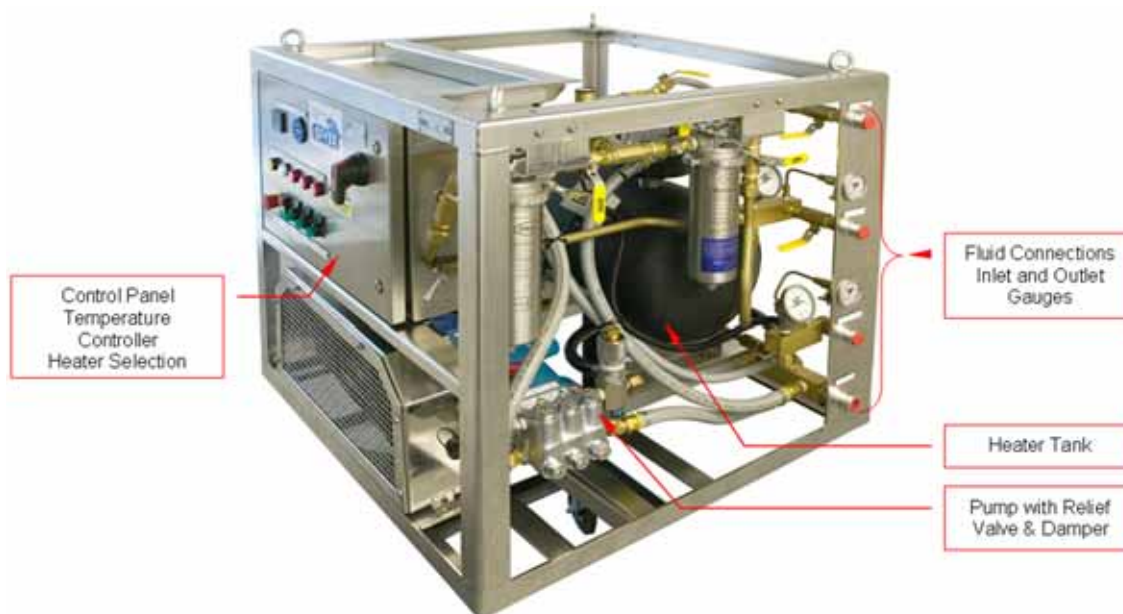

Fig 3.2 General Arrangement

3.1.2 OPERATING START-UP PROCEDURE

1. Pre-operation checks should be done on the following:
 - Machinery is secure – No damage to mountings, brackets, pipe connections etc.
 - Belt drive – In a good condition, belts correctly tensioned and belt guard secure.
 - Pipe work and valves – Secure with no leaks.
 - Filter units – Check that clean cartridges are fitted to the units
 - Water supply and drain – Drain line unrestricted and supply operating correctly.
 - Electrical connections – Electrical fittings and cables are secure and undamaged.
 - Switches – Electrical breakers and isolator are switched to the on position.
 - Emergency switch – Check that the switch is de-activated
2. Open sea water supply valve and allow water to flow through the system. If the indicated pressure drop across the inlet filters exceeds 1 bar the filter cartridge may need to be changed to maintain optimum performance.
3. Check inlet water temperature and determine required temperature settings. See **Section 3.1**
4. Press the pump start button. The pump should start and no the fault indicator lights should be illuminated. If any faults are present refer to **Section 5.1 & 5.2** for troubleshooting.
5. Enter the required outlet temperature into the controller as the control set point value (SV). (See **Section 2.2.2** step no. 4.).
6. Turn on the appropriate heater banks as deduced in the procedure outlined in **Section 3.1**.

The system should now be operating and all systems functioning correctly. Allow the outlet temperature to rise to the set point and monitor the control of the process to confirm correct heater bank selection and temperature output.

IMPORTANT

The supply inlet pressure should be maintained above 3 bar with a sufficient flow rate to supply the unit with a minimum of 30 lit/min. The positive displacement pump will generate an output pressure equivalent to the differential pressure drop through the hose or umbilical while maintaining a constant flow rate.

3.1.3 SHUTDOWN PROCEDURE

1. Turn off all electric heaters.
2. Push Pump Stop Button.
3. Turn off main power switch.
4. Shut sea water valve and open fresh water valve to flush the entire system with fresh water for at least 15 to 20 minutes after each usage. This will flush out the heating system, plumbing, valves, umbilical and most important, the breathing gas heat exchanger and the hot water suit. If required, run the pump to ensure adequate flushing of the system pipe work with fresh water.

IMPORTANT

During the flushing process ensure that the entire system is flushed out by momentarily opening the venting valve and both dump valves.

5. Shut fresh water valve off. Open the drain valve and tank vent valve and allow water to drain from the system.



CAUTION

Drain System

To prevent damage due to freezing of water in the system it is important to drain all the water before storing the unit. In warmer climates draining the system may not be necessary. However, flushing the unit remains necessary prior to storage, especially to prevent corrosion of stainless steel components by stagnant sea water.

CHAPTER 4 MAINTENANCE

4.1 ROUTINE MAINTENANCE

Good maintenance practices are essential to ensure satisfactory operation and extend the service life of the equipment. All steel and painted parts should be periodically cleaned and repainted where necessary.

4.1.1 PERIODIC MAINTENANCE

Periodic maintenance of the unit should be conducted in order to identify and replace worn components. The following are components that must be inspected:

- **Belts** – The drive belts should be checked for wear periodically depending on how often the machine is operated. Belts may need to be replaced due to wear after periods of high duty or due to deterioration after long periods spent out of service. Following periods where the unit has been out of service, the pulley grooves should be checked for corrosion and all moving parts should be thoroughly inspected. Belt tension should be checked regularly.
- **Inlet Filters** – The inlet water filter elements should be checked following the first few hours of operation in a new installation and after long periods spent out of service. Under normal working conditions the filters should be changed when the pressure drop across the filter units rises above 1 bar. The pressure drop across the filters is deduced by subtracting the outlet pressure indicated on the filter gauge from the inlet pressure gauge. The two filters are arranged with valves to allow the isolation of each filter for service. The unit is designed to run using a single filter.
- **Anode Plugs** – Three zinc anodes are mounted in the heater tank. These provide sacrificial corrosion protection to the system and will deteriorate. They should be inspected regularly and replaced when necessary.
- **Heater Elements** – Heater element cover plates should be removed to check for leaks and, if necessary, check element insulation. To remove any elements use WHE-03 element socket, Divex part no. 05547.

IMPORTANT

Heated sea water is extremely corrosive and heater elements will not last indefinitely. Always keep sufficient spare elements available.

4.2 PUMP MAINTENANCE

4.2.1 HELPFUL INFORMATION

(Refer to the Pump Specific Fault Diagnosis and Maintenance table in **Section 5.1**. Refer to **APPENDIX I** for the detailed pump manual)

Interpreting Pressure Readings – Abnormal pressure readings that are out of the specified range during normal operation may indicate a fault or problem with the pump.

IMPORTANT
<p>Pressure irregularities are not a definitive diagnosis of pump faults and it is essential to carry out full fault finding in order to maintain the unit operation.</p>

Before servicing the pump it is prudent to carry out checks on the following:

- Inlet plumbing for size
- Restriction and/or air leaks
- Restricted or worn orifice
- Condition of the by-pass valve
- Condition of the pressure gauge
- Shut-off valves in the inlet or discharge plumbing to be sure they are fully open

Pump Service – Divex advises that the service of the CAT pump on the MHE-02 unit should be carried out by an approved CAT service agent or Divex regional office.

Filter Inspection – The most common cause of low pump pressure is damage due to foreign matter carried in the fluid being pumped. Small abrasive particles in the fluid may damage the pump valves, valve seats, cylinder walls, cups and block the filter screens. It is essential to ensure that the fluid being pumped is properly filtered to increase the service life of the pump. The inline filter cartridges of the MHE-02 should be inspected and replaced at regular intervals as required. The unit should not be run with blocked or damaged filter cartridges or without filter cartridges in the filter housings as this may cause damage the pump.

4.2.2 PUMP SPECIFICATIONS

	MHE-02 SETUP	SPECIFICATION
Flow Rate (Max)	30 l/min	45 l/min [Max]
Pressure Range	7 to 155 bar	7 to 155 bar
Inlet Pressure Range	1.4 to 4 bar	1.4 to 4 bar
Speed (Maximum Allowable)	767 rev/min	1150 rev/min [Max]
Maximum Fluid Temperature	71°C	71°C
Crankcase Capacity	1.26 ltr	1.26 ltr
Inlet Ports	$\frac{3}{4}$ " NPTF	$\frac{3}{4}$ " NPTF
Discharge Ports	$\frac{1}{2}$ " NPTF	$\frac{1}{2}$ " NPTF
Pulley Mounting	Either Side	Either Side
Shaft Diameter	30 mm	30 mm
Weight	19.9 kg	19.9 kg

(Intentionally Blank)

CHAPTER 5 TROUBLESHOOTING

The tables in this section are designed as a troubleshooting guide to aid in the identification of faults and outline possible corrective action.

5.1 PUMP SPECIFIC FAULT DIAGNOSIS AND MAINTENANCE

PROBLEM	POSSIBLE CAUSE	SOLUTION
Pulsation	Faulty Pulsation Damper.	Check pre-charge of pulsation Damper; if low, recharge or install a replacement component.
Low Pressure	Belt slippage.	Tighten or replace; use correct belt.
	Air leak in inlet plumbing.	Disassemble, reseal, and re-assemble.
	Pressure gauge inoperative or not registering accurately.	Check with new gauge; replace faulty gauge.
	Relief valve stuck, partially plugged or improperly adjusted, valve seat worn.	Clean and adjust relief valve; check for worn and dirty valve seats. Replace worn parts.
	Inlet filter clogged or improperly size.	Clean. Use 50 micron filter element. Check more frequently.
	Worn packing. Abrasives in pumped fluid or severe cavitation. Inadequate water supply.	Install proper filter. Check fluid supply available to the pump.
Low Pressure	Fouled or dirty inlet or discharge valves	Clean inlet and discharge valve assemblies.
	Worn inlet or discharge valves.	Replace worn valves, valve seats and/or discharge hose.
	Leaking discharge hose.	
Pump runs extremely rough, pressure very low	Restricted inlet or air entering the inlet plumbing.	Size inlet plumbing correctly; check for air tight seals.
	Inlet restrictions or stuck inlet or discharge valve.	Clean out foreign material.
	Leaking HP seals.	Replace worn seals.
Water leakage from under the inlet manifold	Worn packing.	Install new packing.
	Worn male and female adaptor.	Install new male and female adaptor.

PROBLEM	POSSIBLE CAUSE	SOLUTION
Oil leak between crankcase and pumping section	Worn crankcase piston rod seals.	Replace crankcase piston rod seals.
Oil leaking in the crankshaft area	Worn crankshaft seal or improperly installed oil seal retainer o-ring.	Remove oil seal retainer and replace damaged o-ring and/or seals.
	Worn bearing.	Replace bearing.
Excessive play on the crank shaft pulley	Worn main bearing from excessive tension on drive belt.	Replace bearing. Properly tension belt.
Water in crankcase	May be caused by humid air condensing into water inside the crankcase.	Change oil at 3 month or 500 hour intervals using Divex part no. DO03764.
	Leakage of packing seals. Over-pressure or faulty pressure regulator.	Replace packing. Check pressure regulator.
Oil leaking from underside of crankcase	Worn crankcase seals.	Replace seals.
Oil leaking at the rear portion of the crankcase	Damaged or improperly installed oil gauge or crankcase rear cover o-ring, and drain plug o-ring.	Replace oil gauge or cover o-ring and drain plug o-ring.
Oil leaking from drain plug	Loose drain plug or worn drain plug o-ring.	Tighten drain plug or replace o-ring.
Loud knocking noise in pump	Pulley loose on crankshaft.	Check key and tighten set screw.
	Broken or worn bearing.	Replace bearings.
Frequent or premature failure of the inlet manifold seals	Scored plungers.	Replace plungers.
	Over pressure to inlet manifold.	Reduce inlet pressure per instructions.
	Damaged or worn plungers.	Replace the plungers.
	Abrasive material in the fluid being pumped.	Install proper filtration on pump inlet plumbing.
	Excessive pressure and/or temperature of fluid being pumped.	Check pressures and fluid inlet temperature; be sure they are within specified range.
	Over pressure of pumps.	Reduce supply pressure.
	Running pump dry.	Do not run pump without water.

PROBLEM	POSSIBLE CAUSE	SOLUTION
Strong surging at inlet and low pressure on discharge side	Foreign particles in the inlet or discharge valve or worn inlet and/or discharge valves.	Check for smooth lap surfaces on inlet and discharge valve seals. Discharge valve seals and inlet valve seals may be lapped on a very fine oil stone.

5.2 GENERAL TROUBLESHOOTING CHART

PROBLEM	POSSIBLE CAUSE	SOLUTION
Low output pressure	Leaking Relief Valve.	Check relief valve function, repair or replace.
	Water inlet to system low or turned off.	Turn inlet water on. Check water supply and hose sizing.
	Insufficient flow in water feed lines to system.	Check inlet hose diameter is sufficient and is not restricted or crushed.
	Low pressure in umbilical line or system.	This is expected. As the system's output depends upon the flow resistance, if there is low resistance the pressure will be low but the flow rate will be maintained.
Water will not heat	Circuit breakers tripped in heating circuits.	Switch off - reset breaker(s). If breaker(s) trip again when switched on, investigate cause. (In an emergency faulty element banks may be switched off, leaving other banks operational).
	Manual overboard dump valve open.	Close manual overboard dump valve.
	Temperature control valve is stuck in the fully open position due to valve or actuator failure.	Check the actuator function by manipulating the actuator manually. If the valve cannot be turned manually service or replace the control valve. If the actuator does not return when released from manual disturbance repair or replace the actuator.
Relief valve will not close	Dirt lodged in seat of relief valve.	Clean seat of relief valve, reset and test.

PROBLEM	POSSIBLE CAUSE	SOLUTION
Motor fault - will not run	Fault in wiring to contactor, control circuit or main control circuit is broken.	Trace wiring; make sure there is no broken circuit to wiring. If there is, correct malfunction. If main power control circuit is open, it may be due to some other fault in system such as low water, over temperature relay created open circuit, or float switch indicating low water. If any of these fault indicators are activated, corrective action is required.
	Overload relay tripped.	Reset overload relay and make sure that relay is set in the "automatic" position.
	Defective pump motor contactor.	Remove and replace.
	Burned out motor.	Replace motor.
Pump chattering loudly	Low inlet water pressure with restricted flow.	Increase inlet water pressure and flow rate to unit.
	Pump "pressure reducing" regulator malfunction.	Clean regulator and reassemble. If unit will not regulate pressure on pump to between 2.5 and 4 bar, replace regulator. EMERGENCY CORRECTIVE ACTION Bypassing the regulator will allow operation in an emergency but this is not recommended as this will put increased load and wear on pump as well as causing seals to leak and allow water into crankcase. Refer to Pump Specific Troubleshooting, section 5.1 .
Sea water mixing with fresh water	Faulty check valve in sea water circuit.	Remove, clean reassemble or replace.
Hot water output will not maintain control	Too many or too few heaters on.	Check graphs and table to determine amount of heat necessary.
	Temperature Control valve faulty.	Clean and check or replace. EMERGENCY CORRECTIVE ACTION Shut temperature control valve off by depressing the button on the side of the valve actuator housing and turn the lever fully clockwise to close the valve. Then use the manual bypass valve to manually control output temperature.

PROBLEM	POSSIBLE CAUSE	SOLUTION
Large flow in overboard dump line	Leaking relief valve.	Clean relief valve and reset. If valve continues to leak, replace.
Large flow in overboard dump line	Overboard dump valve left open.	Close valve.
	Too many heaters on for load on system.	Refer to table to determine proper number of heaters on or shut one heater off and monitor temperature.
System will not run, fault light is on	No water is coming to system. Float switch shut off.	Supply water to system and purge. Make sure that water is flowing out of system through umbilical hose.
	Faulty float switch.	Repair or replace float switch.
	Overheated water in the heater tank.	Make sure that water is flowing through the system.
	No water in heater tank.	Re-prime system, making sure that water is flowing through system.
	Over temperature control needs adjustment.	Readjust over temperature controls, whichever one is turning the system off if temperature of water is low.
	Faulty over temperature switch.	Determine which over temperature switch is open circuited and replace. Refer to the electrical schematics for wiring details.
System will not run, pump overload fault light is on	Pump overload relay has tripped.	Possible low voltage, single phase or incorrect frequency. Check the input voltage and frequency. Measure the current on the pump motor to see if it's within rating. Reset overload and start system again.
	Faulty fault indicator relay, R1/R2.	Replace.
	Faulty overload relay.	Replace.
Inlet pressure to pump is low	Faulty pressure regulator.	Replace.
	Low pressure to system, below 3.5 bar.	Increase pressure and flow rate to the system.
Pump varies in speed	Belts slipping.	Check tension on belts. If tension is loose, tighten belt by adjusting tension bolts on motor mount.
		Check belts condition. If belts are torn, ragged, or in poor condition, replace.

PROBLEM	POSSIBLE CAUSE	SOLUTION
Water temperature will not rise adequately	Insufficient number of heaters on for load.	Turn on one additional heater. Check Heater Selection Table 3.1 .
Contactors buzzing	Dirt, debris or rust on pole pieces of contactors.	Disassemble contactor and sand pole pieces and clean.
	Low frequency on system.	Check frequency. If frequency is below 50 Hz, see if frequency can be increased.
	Faulty contactor.	Replace.
Contactors will not close	Open circuit in wiring to holding coil.	Check wiring and if required replace broken wire.
	Faulty holding coil.	Replace.
	Faulty contactor.	Replace.
System will not start	Input power off.	Check input power. Check fault indicator lights to see if any lights are on. If any fault lights are on, remedy fault. Example: low water. Water to system shut off and float switch will open thus keeping system off.
	Main power switch not turned on.	Turn switch on.
	Control Circuit Breaker tripped.	Check, reset. If faulty replace.
	Faulty main power contactor.	Replace.
Pump turns on and off rapidly	Faulty overload relay.	Replace.
	Motor shorted.	Replace.
Pump will not run for long periods of time without overloading	Low voltage to system.	Check voltage. If voltage is not a minimum of 420 V, pump will overload.
	Pump is corroded or jammed inside and very difficult to turn.	Check pump to see if there are any mechanical problem with it. If there is, the pump must be repaired. See Pump Troubleshooting, section 5.1 .
Heater shuts off with water less than 70°C (160°F)	Over temperature switch set incorrectly.	Reset over temperature switch to 70°C (160°F).

PROBLEM	POSSIBLE CAUSE	SOLUTION
Contactors will not open	Faulty contactor.	Replace.
	Shorted wire on holding coil.	Check out wiring for short and repair.
System inoperable, no fault indicator	Burned out fault light.	Replace.
	Faulty fault relays, R1 and R2.	Replace.
No 24 VDC control power	Control transformer faulty.	Check output of power supply. If it is not 24 V on the feed with 380 V on the supply, replace power supply unit.
	Control power fuse F3 burned out.	Replace.
Fault lights will not come on	Faulty fault relays.	Replace.
	Burned out fault lights.	Replace.

(Intentionally Blank)

APPENDIX A PART IDENTIFICATION

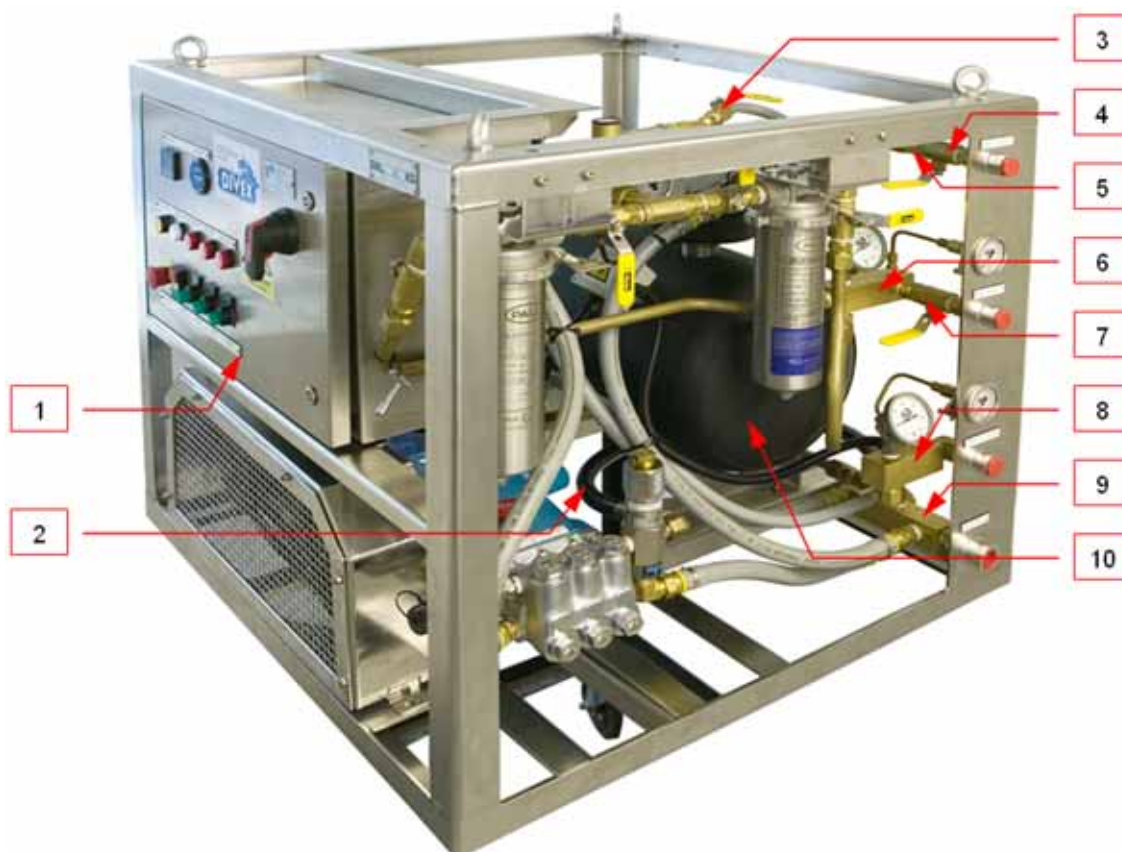

Fig A.1 MHE-02 General Arrangement - Isometric View

ITEM	DESCRIPTION	DIVEX PART NO.
1	Control Panel	-
2	HP Hose Assembly	DO 06035
3	Ball Valve, ½" NPT, (<i>Heater Tank Bleed Valve</i>)	XV500P-8-02
4	Ball Valve, ¾", Brass, (<i>Fresh Water Inlet Shut-off Valve</i>)	XV500P-12-02
5	Check Valve ¾"	DO 02780
6	Sea Water In Manifold	DO 05955
7	Ball Valve ¾" NPT. Brass, (<i>Sea Water Supply Shut-off</i>)	XVP500P-12-02
8	Hot Water Manifold	DO 05957
9	Dump Manifold	DO 05956
10	Heater Tank Assembly	DO 05969

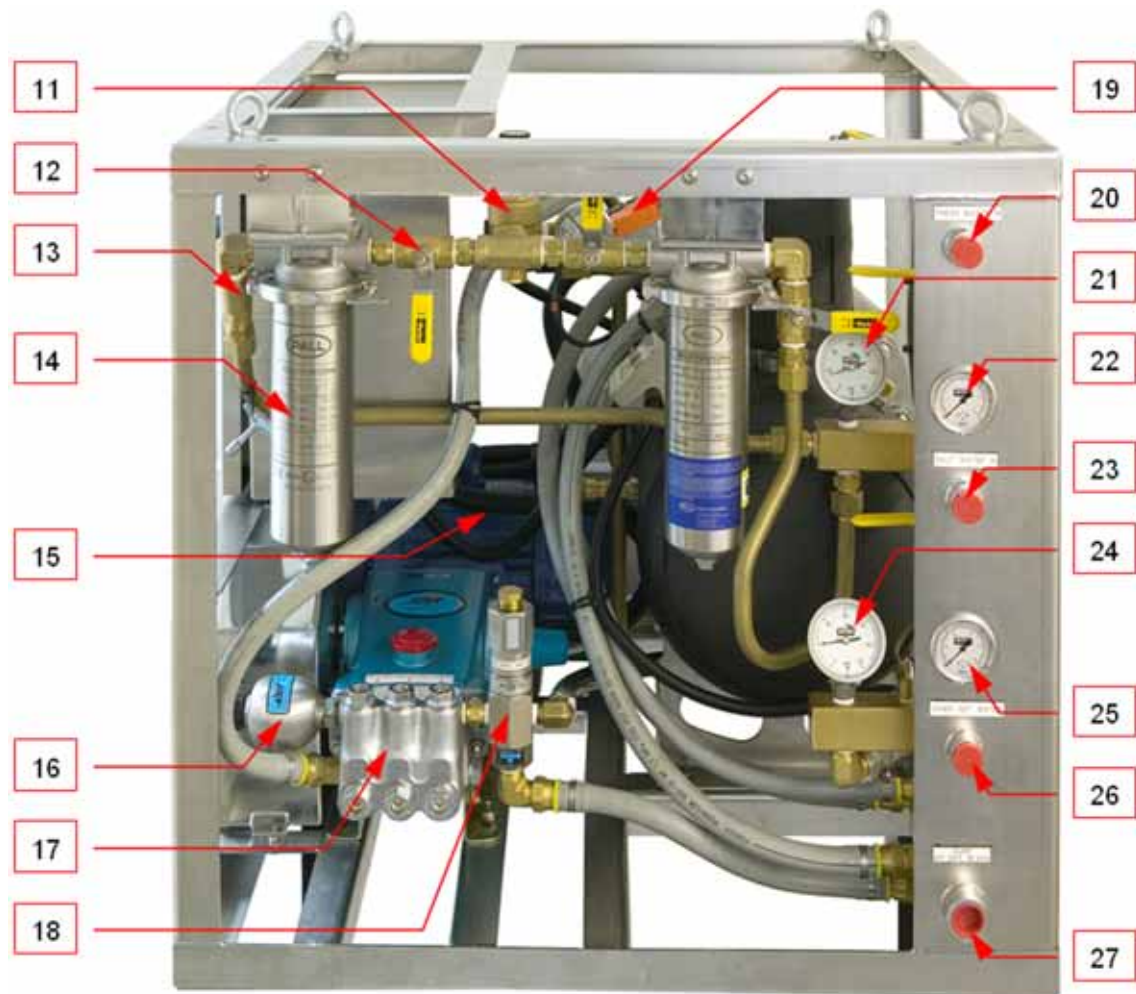

Fig A.2 MHE-02 General Arrangement - Side View

ITEM	DESCRIPTION	DIVEX PART NO.
11	Pressure Reducing Valve 5360 3/4	DO 02359
12	Ball Valve 3/4" NPT, (Filter Isolation Valves)	XV500P-12-02
13	Ball Valve 3/4" NPT, (Filter Isolation Valves)	XV500P-12-02
14	Filter Housing 3/4" NPT, (With 50µ Filter Element DSA No. DO 04793)	DO 04768
15	Motor, 4kW – 4 pole	DO 06051
16	Accumulator CAT S/S	DO 02724
17	Pump CAT	DO027221
18	Pressure Regulator CAT	DO 02723
19	Control Ball Valve/ Rotary Actuator 3/4" NPT	DO 02788
20	Fresh Water Inlet Connection 3/4" NPT	-
21	Gauge, Temp., 0-100°C Swivel Brkt. (Inlet Water Temperature Gauge)	DO 06068

ITEM	DESCRIPTION	DIVEX PART NO.
22	Gauge Pressure 0-10 bar Back Entry (<i>Inlet Water Pressure Gauge</i>)	PBBV63BB02QJ2A
23	Sea Water Inlet Connection ¾" NPT	-
24	Gauge, Temp., 0-100°C Swivel Brkt. (<i>Inlet Water Temperature Gauge</i>)	DO 06068
25	Gauge Pressure 0-100 bar Back Entry (<i>Outlet Water Pressure Gauge</i>)	PBBV63BB02QJ3A
26	Hot Water Outlet Connection ¾" NPT	-
27	Dump/Drain Connection 1" NPT	-

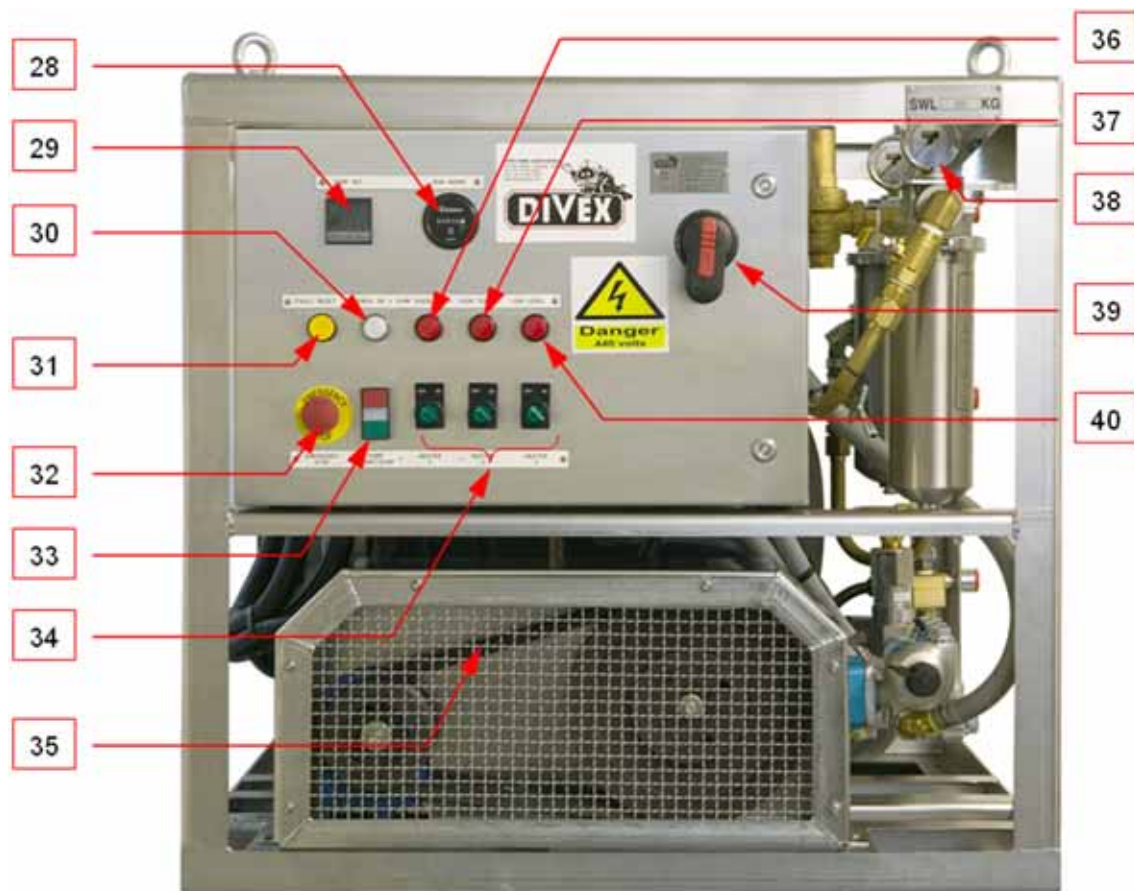

Fig A.3 MHE-02 General Arrangement – Front View

ITEM	DESCRIPTION	DIVEX PART NO.
28	Hour Meter 10-80VDC	DO 03903
29	Controller Temperature RKC	DO 03900
30	Control Power On Indication Lamp	DO 04991
31	Fault Reset Push Button	DO 04838 + DO 02889 + DO 02889
32	Emergency Stop	DO 03260 + DO 02891 + DO 04827
33	Start/Stop Switch (Pump)	DO 04823 + DO 02891 + DO 02889 + DO 06033
34	Heater Bank Rotary Selector Switches (3 off)	DO 06031 + DO 02889 + DO 06032
35	Belt SPB x 1260 (2 off, Matched Pair)	DO 05040
36	Pump Overload Indication	DO 04992
37	Over Temperature Indication	DO 04992
38	Gauge Pressure 0-10 bar Bottom Entry (Filter Outlet Pressure Indication Gauge)	PBBA63BB02QJ2A
39	Isolator 160A 3-Pole OT160	DO 03347
40	Low Water Level Indication	DO 04992

APPENDIX B RECOMMENDED SPARE PARTS LIST & ACQUISITION FORM

B.1 RECOMMENDED SPARE PARTS LIST - (SPARES KIT - KI40026AA-KIT)

DESCRIPTION	QTY	DIVEX SA PART NO.	SHOWN AS
HP Hose Assembly	1	DO 06035	Item 2, Fig A.1
Valve Ball, 1/2" NPT Brass	1	XV500P-8-02	Item 3, Fig A.1
Valve Ball, 3/4"NPT, Brass	3	XV500P-12-02	Item 4, Fig A.1
Valve Check Brass 3/4" Euro Stop	1	DO 02780	Item 5, Fig A.1
Manifold MHE-2 Sea Water In CZ121	-	DO 05955	Item 6, Fig A.1
Manifold MHE-2 Hot Water CZ121	-	DO 05957	Item 8, Fig A.1
Manifold MHE-2 Dump CZ121	-	DO 05956	Item 9, Fig A.1
Valve Pressure Reducing 3/4" Brass	1	DO 02359	Item 11, Fig A.2
Filter Housing 3/4" NPT,	-	DO 04768	Item 14, Fig A.2
50µ Filter Element, 10"	4	DO 04793	Item 14, Fig A.2
Motor Electric 4kW 4 pole 380v 3phase	1	DO 06051	Item 15, Fig A.2
Accumulator CAT S/S	1	DO 02724	Item 16, Fig A.2
Pump CAT	1	DO 027221	Item 17, Fig A.2
Valve, Pressure Regulator	1	DO 02723	Item 18, Fig A.2
Valve 2 Way Proportional Actuated 3/4" NPT	1	DO 02788	Item 19, Fig A.2
Gauge, Temp., 0-100°C Dial Every Angle	1	DO 06068	Item 21 & 24, Fig A.2
Gauge Pressure 0-10 bar Back Entry	1	PBBV63BB02QJ2A	Item 22, Fig A.2
Gauge Pressure 0-100 bar Back Entry	1	PBBV63BB02QJ3A	Item 25, Fig A.2
Hour Meter 10-80VDC	1	DO 03903	Item 28, Fig A.3
Controller Temperature RKC	1	DO 03900	Item 29, Fig A.3
Light Pilot LED Cluster 24VAC/DC White	1	DO 04991	Item 30, Fig A.3
Fault Reset Push Button	1	DO 04838	Item 31, Fig A.3
Contact Element N/O Contact Block	3	DO 02889	Item 31, 33, 34
Actuator E-Stop Latching Mushroom RED	-	DO 03260	Item 32, Fig A.3
Contact Element N/C Contact Block	2	DO 02891	Item 32, 33
Legend, Emergency Stop	-	DO 04827	Item 32
Switch Start/Stop c/w Pilot Light Switch	1	DO 04823	Item 33, Fig A.3
Indicator LED Module White 18-30 VAC/DC	1	DO 06033	Item 33
Switch Selector Illuminated GRN	1	DO 06031	Item 34, Fig A.3
Indicator LED Module Green 18-30 VAC/DC	3	DO 06032	Item 36, 37, 40
Belt SPB x 1260	2	DO 05040	Item 35, Fig A.3

DESCRIPTION	QTY	DIVEX SA PART NO.	SHOWN AS
Light Pilot LED Cluster 24VAC/DC RED	3	DO 04992	Item 36-38, Fig A.3
Gauge Pressure 0-10 bar Bottom Entry	1	PBBA63BB02QJ2A	Item 38, Fig A.3
Isolator Mains 160A 3-Pole	-	DO 03347	Item 39, Fig A.3
Element 4.5kW 1-1/4" BSP, 380VAC	15	DO 05159	*
Switch Level SS 1" NPT Ball/Lever	1	DO 02779	*
PT100 55mm Probe	1	DO 03901	*
Thermo pocket 316 SS 20mm PKT, 1/2" NPT x M20	-	DO 06369	*
Thermostat Mechanical RS11 11" Long	1	DO 02374	*
Pocket Thermostat 1 1/4" BSP Brass Boss	-	DO 03961	*
Anode 1/2" NPT Brass + 100mm Zinc	6	DO 02369	*
Gasket Flange WHE-3	1	DO 04692	*
Neoprene Gasket 2mm thk 364mm Dia	1	DO 02760	*
Valve Relief 1/2" MNPT 3-50 PSI Brass	1	DO 02304	*
Valve Globe 3/4" NPT Brass	1	DO 03326	*
Oil Divex CAT Pump Lubeb [litres]	0.5	DO 03764	*
Circuit Breaker Miniature 50A 6kA 3pole	2	DO 05934	*
Circuit Breaker Miniature 20A 6kA 3pole	2	DO 05932	*
Circuit Breaker Miniature 32A 6kA 3pole	1	DO 05933	*
Contactors 11kW 3pole 24V	2	DO 05936	*
Contactors 7.5kW 3pole 24V	2	DO 05935	*
Diode Safety Back EMF 24-48V	5	DO 05937	*
Overload Thermal 10-15A	1	DO 05938	*
Power Supply 340-550V 24VDC 5A	1	DO 03904	*
Timer On-Delay 24VDC	1	DO 04840	*
Relay Base Socket Din Rail Mount	1	DO 04173	*
Relay Miniature 24VDC Coil 4 C/O	3	DO 04171	*
Module Diode Plug-In 6 - 220 VDC	3	DO 03910	*
Terminal Din Rail Earth 0.5 - 4mm	-	DO 02936	*
Terminal Din Rail 0.5 - 4.0mm	-	DO 02901	*
Terminal Fuse 5x20mm	-	DO 03902	*
Fuse Glass 5 x 20 5 Amp	10	DO 03914	*
Fuse Glass 5 x 20 1 Amp	10	DO 03913	*
Label Heater Selection MHE-02	-	DO 06358	*

(* Item not shown in document)

B.2 RECOMMENDED SPARE PARTS – (NOT IN SPARES KIT KI040026AA - KIT)

DESCRIPTION	QTY	DIVEX SA PART NO.	SHOWN AS
Label Heater Selection MHE-02	-	DO 06055	*
Manifold MHE-2 Sea Water In CZ121	-	DO 05955	Item 6, Fig A.1
Manifold MHE-2 Hot Water CZ121	-	DO 05957	Item 8, Fig A.1
Manifold MHE-2 Dump CZ121	-	DO 05956	Item 9, Fig A.1
Filter Housing ¾" NPT,	-	DO 04768	Item 14, Fig A.2
Actuator E-Stop Latching Mushroom RED	-	DO 03260	Item 32, Fig A.3
Legend, Emergency Stop	-	DO 04827	Item 32
Isolator Mains 160A 3-Pole	-	DO 03347	Item 39, Fig A.3
Thermo pocket 316 SS 20mm PKT, ½" NPT x M20	-	DO 06369	*
Pocket Thermostat 1 ¼" BSP Brass Boss	-	DO 03961	*
Terminal Din Rail Earth 0.5 - 4mm	-	DO 02936	*
Terminal Din Rail 0.5 - 4.0mm	-	DO 02901	*
Terminal Fuse 5x20mm	-	DO 03902	*

(* Item not shown in document)

(Intentionally Blank)

APPENDIX C SPARES ACQUISITION SHEET

MHE Serial No:	MHE / /				
Request for: (mark appropriate)	Quotation & Delivery Details	YES	NO	Order Date:	DD / MM / YYYY
	Supply Based on Order No.	YES	NO	Order No:	

NOTE

Please attach full contact details to this sheet when placing orders and fill in required quantities in the table below before faxing or e-mailing this request to the nearest Divex office for attention.

DESCRIPTION	DIVEX SA PART NO.	QTY
HP Hose Assembly	DO 06035	
Valve Ball, 1/2" NPT Brass	XV500P-8-02	
Valve Ball, 3/4"NPT, Brass	XV500P-12-02	
Valve Check Brass 3/4" Euro Stop	DO 02780	
Valve Pressure Reducing 3/4" Brass	DO 02359	
Cartridge, Pressure Reducing Valve 3/4" Brass	DO 02359-C	
50µ Filter Element, 10"	DO 04793	
Motor Electric 4kW 4 pole 440v 3phase	DO 06051	
Accumulator CAT S/S	DO 02724	
Pump CAT	DO 02721	
Valve, Pressure Regulator	DO 02723	
Valve 2 Way Proportional Actuated 3/4" NPT	DO 02788	
Gauge, Temp., 0-100°C Dial Every Angle	DO 06068	

DESCRIPTION	DIVEX SA PART NO.	QTY
Valve Relief 1/2"MNPT 3-50 PSI Brass	DO 02304	
Valve Globe 3/4"NPT Brass	DO 03326	
Oil Divex CAT Pump Lubeb [litres]	DO 03764	
Circuit Breaker Miniature 50A 6kA 3pole	DO 05934	
Circuit Breaker Miniature 20A 6kA 3pole	DO 05932	
Circuit Breaker Miniature 32A 6kA 3pole	DO 05933	
Contactors 11kW 3pole 24V	DO 05936	
Contactors 7.5kW 3pole 24V	DO 05935	
Diode Safety Back EMF 24-48V	DO 05937	
Overload Thermal 10-15A	DO 05938	
Power Supply 340-550V 24VDC 5A	DO 03904	
Timer On-Delay 24VDC	DO 04840	
Relay Base Socket Din Rail Mount	DO 04173	

DESCRIPTION	DIVEX SA PART NO.	QTY
Gauge Pressure 0-10 bar Back Entry	PBBV63BB02 QJ2A	
Gauge Pressure 0-100 bar Back Entry	PBBV63BB02 QJ3A	
Hour Meter 10-80VDC	DO 03903	
Controller Temperature RKC	DO 03900	
Light Pilot LED Cluster 24VAC/DC White	DO 04991	
Fault Reset Push Button	DO 04838	
Contact Element N/O Contact Block	DO 02889	
Contact Element N/C Contact Block	DO 02891	
Switch Start/Stop c/w Pilot Light Switch	DO 04823	
Indicator LED Module White 18-30 VAC/DC	DO 06033	
Switch Selector Illuminated GRN	DO 06031	
Indicator LED Module Green 18-30 VAC/DC	DO 06032	
Belt SPB x 1260	DO 05040	
Light Pilot LED Cluster 24VAC/DC RED	DO 04992	
Gauge Pressure 0-10 bar Bottom Entry	PBBA63BB02 QJ2A	
Element 4.5kW 1-1/4" BSP	DO 02776	
Switch Level SS 1" NPT Ball/Lever	DO 02779	
PT100 55mm Probe	DO 03901	
Thermostat Mechanical RS11 11" Long	DO 02374	
Anode 1/2" NPT Brass + 100mm Zinc	DO 02369	
Gasket Flange WHE-3	DO 04692	

DESCRIPTION	DIVEX SA PART NO.	QTY
Relay Miniature 24VDC Coil 4 C/O	DO 04171	
Module Diode Plug-In 6 - 220 VDC	DO 03910	
Fuse Glass 5 x 20 5 Amp	DO 03914	
Fuse Glass 5 x 20 1 Amp	DO 03913	
Label Heater Selection MHE-02	DO 06055	
Manifold MHE-2 Sea Water In CZ121	DO 05955	
Manifold MHE-2 Hot Water CZ121	DO 05957	
Manifold MHE-2 Dump CZ121	DO 05956	
Filter Housing 3/4" NPT,	DO 04768	
Actuator E-Stop Latching Mushroom RED	DO 03260	
Legend, Emergency Stop	DO 04827	
Isolator Mains 160A 3-Pole	DO 03347	
Thermo pocket 316 SS 20mm PKT, 1/2" NPT x M20	DO 06369	
Pocket Thermostat 1 1/4" BSP Brass Boss	DO 03961	
Terminal Din Rail Earth 0.5 - 4mm	DO 02936	
Terminal Din Rail 0.5 - 4.0mm	DO 02901	
Terminal Fuse 5x20mm	DO 03902	
Neoprene Gasket 2mm thk 364mm Dia	DO 02760	

APPENDIX D WIRING DIAGRAMS

Project: <i>MHE-02</i>	Supplier: <i>Divex Cape Town</i>	Wire Size	Wire Specification	Power Wiring: Phase 1: Brown Phase 2: Black Phase 3: Grey Earth: Green / Yellow Control Wiring: 24 VDC: Red 0 VDC: Black
		0.75mm ²	Silicone Rubber (Type RD7) Insulated (Halogen Free), SANS 1574 & VDE 0282 - (All control wiring in 05793-1)	
Technical Data :	Degree of Protection : <i>IP 55 (Minimum)</i>	2.5mm ²	Silicone Rubber (Type RD7) Insulated (Halogen Free), SANS 1574 & VDE 0282	
		4mm ²	Silicone Rubber (Type RD7) Insulated (Halogen Free), SANS 1574 & VDE 0282	
		6mm ²	Silicone Rubber (Type RD7) Insulated (Halogen Free), SANS 1574 & VDE 0282	
		10mm ²	Silicone Rubber (Type RD7) Insulated (Halogen Free), SANS 1574 & VDE 0282	
Rated Voltage / Frequency : <i>440V @ 60hZ</i>				
Rated Current : <i>130 Amps</i>				
Control Voltage : <i>24vDC</i>				

PANEL LAYOUT

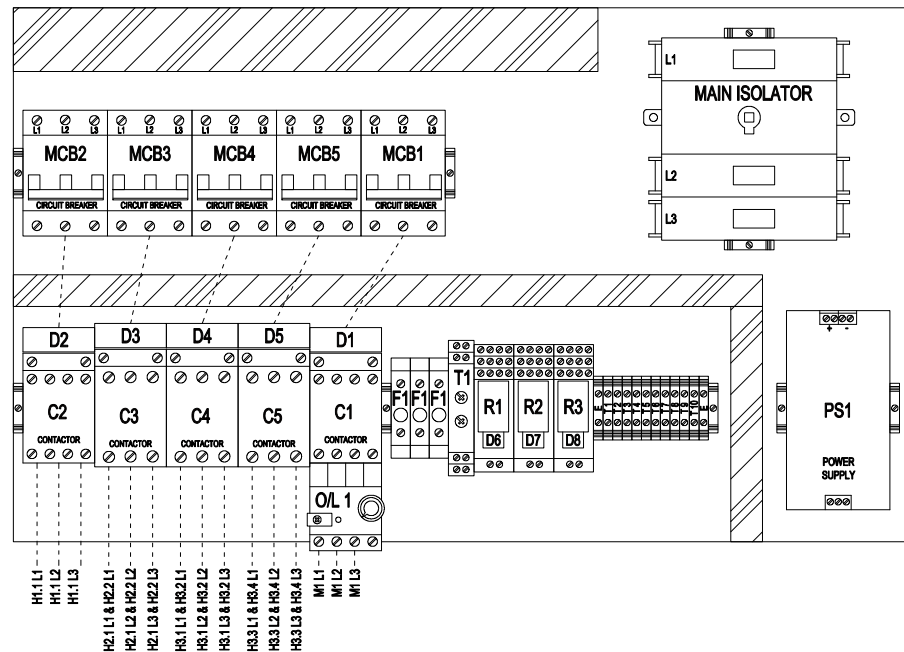

THIRD ANGLE PROJECTION		MATERIAL:		FINISH:		MASS: (kg)		COPYRIGHT EXISTS IN THIS DRAWING AND ALL INFORMATION THEREIN IN TERMS OF COPYRIGHT LAW. THIS DRAWING IS ONLY TO BE USED FOR THE PURPOSE FOR WHICH IT WAS SUPPLIED TO THE SECOND PARTY AND MAY NOT BE REPRODUCED IN WHOLE OR IN PART BY ANY MEANS WHATSOEVER AND ITS CONTENTS MAY NOT BE DISCLOSED TO ANY OTHER PARTY WITHOUT THE CONSENT OF DIVEX (PTY) LTD. NO LICENCE OR RIGHTS TO MANUFACTURE THE EQUIPMENT IS GIVEN OR IMPLIED.				ITEM	QTY	DESCRIPTION	MATERIAL/REMARKS	DRAWING No/PART No				
		-																		
												OVER-TO	±	±	±	SCALE	PRODUCT/PROJECT	TITLE		
												0-6	0.1	0.2	0.5	n/a	MHE-02	MHE-02 ELECTRICAL PANEL LAYOUT		
												6-30	0.2	0.5	1.0	ALL DIMENSIONS IN MM (UOS) DO NOT SCALE	PART No.	06028-0	REV R00	
												30-100	0.3	0.8	1.5					
												100-300	0.5	1.2	2.0					
												300-1000	0.8	2.0	3.0					
												1000-3000	1.2	3.0	5.0					
												3000-PLUS	2.0	4.0	8.0	ALL DIMENSIONS BEFORE PLATING (UOS)	CAD REF/DRG No.	06028-0	SHT	1 OF 1
REV	DESCRIPTION OF REVISION	ECN	DRAWN	DATE	DRAFTING CHECK BY	DATE	ENGINEER CHECK BY	DATE	APPROVAL BY	DATE	REMOVE SHARP EDGES & BURRS									

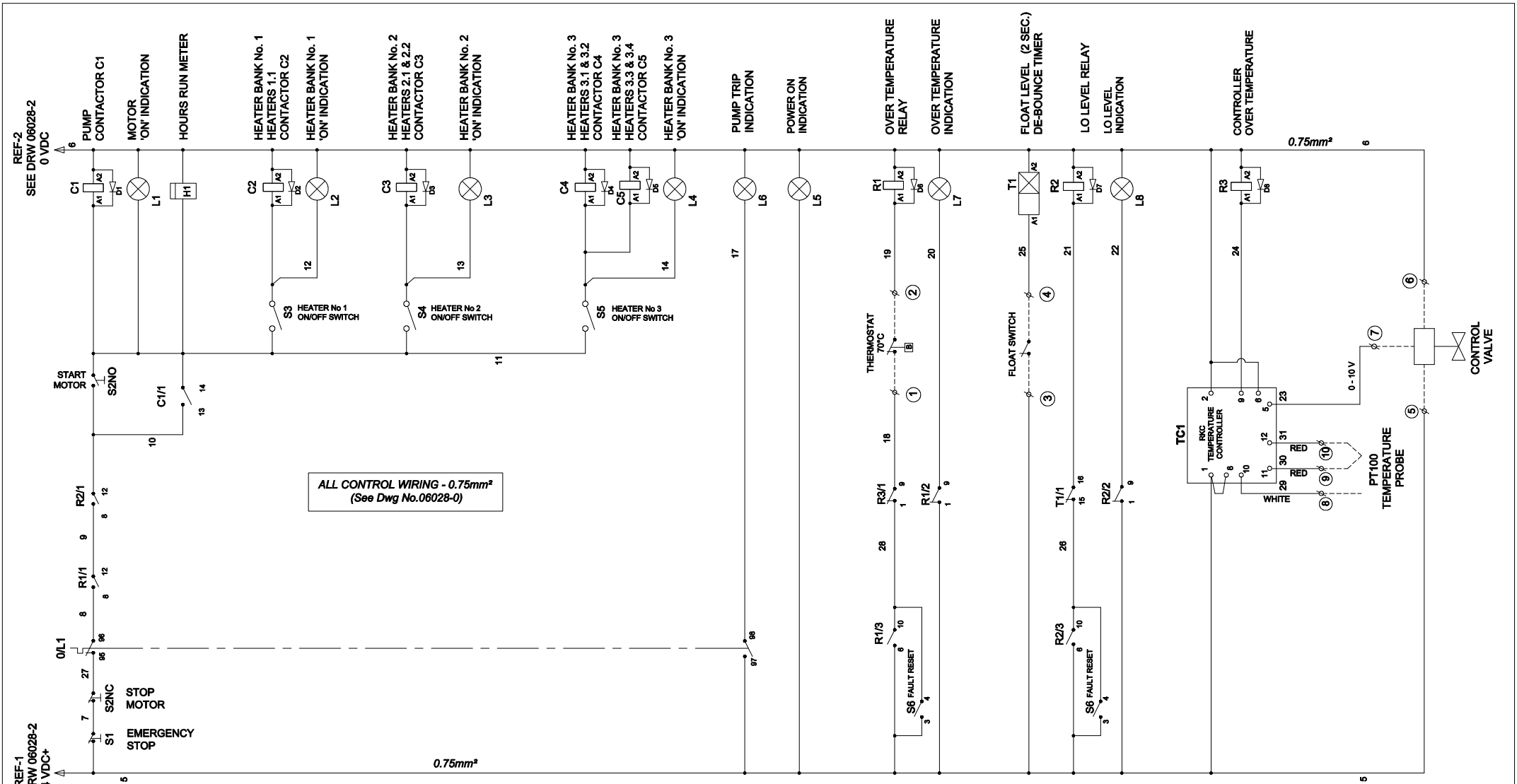

ALL CONTROL WIRING - 0.75mm²
(See Dwg No.06028-0)

0.75mm²

NOTE: '-----' INDICATES EXTERNAL FIELD WIRING

THIRD ANGLE PROJECTION		MATERIAL:		FINISH:		MASS: (kg)		ITEM		QTY		DESCRIPTION		MATERIAL/REMARKS		DRAWING No/PART No			
		-		-		-		<small>COPYRIGHT EXISTS IN THIS DRAWING AND ALL INFORMATION THEREIN IN TERMS OF COPYRIGHT LAW. THIS DRAWING IS ONLY TO BE USED FOR THE PURPOSE FOR WHICH IT WAS SUPPLIED TO THE SECOND PARTY AND MAY NOT BE REPRODUCED IN WHOLE OR IN PART BY ANY MEANS WHATSOEVER AND ITS CONTENTS MAY NOT BE DISCLOSED TO ANY OTHER PARTY WITHOUT THE CONSENT OF DIVEX (PTY) LTD. NO LICENCE OR RIGHTS TO MANUFACTURE THE EQUIPMENT IS GIVEN OR IMPLIED.</small>								DIVEX (PTY) LTD CAPE TOWN, SOUTH AFRICA P.O. BOX 38541, CHEMPET, 7442 TEL: +27 (0)21 551-2233 FAX: +27 (0)21 552-3547 www.divexglobal.com			
		-		-		-		OVER-TO ± ± ± 0-6 0.1 0.2 0.5 6-30 0.2 0.5 1.0 30-100 0.3 0.8 1.5 100-300 0.5 1.2 2.0 300-1000 0.8 2.0 3.0 1000-3000 1.2 3.0 5.0 3000-PLUS 2.0 4.0 8.0 ANGLE 0.25° 0.5° 1°		SCALE		PRODUCT/PROJECT		TITLE		PART No.		REV	
								N.T.S.		MHE-02		MHE-02 ELECTRICAL SCHEMATIC 24 VDC CONTROL CIRCUIT		06028-1		REV R01			
R01 AMENDED AS PER ECN: CT-00276		-		R.C.		18/06/10 D.H. 18/06/10 G.D.		18/06/10 R.F.		18/06/10		ALL DIMENSIONS IN MM (UOS) DO NOT SCALE		06028-1					
R00 FIRST ISSUE		-		R.C.		12/08/09 D.H. 12/08/09 G.D.		20/08/09 R.F.		01/09/09		ALL DIMENSIONS BEFORE PLATING (UOS)		06028-1					
REV DESCRIPTION OF REVISION		ECN		DRAWN DATE		DRAFTING CHECK BY DATE		ENGINEER CHECK BY DATE		APPROVAL BY DATE		REMOVE SHARP EDGES & BURRS		06028-1		SHT 1 OF 1			

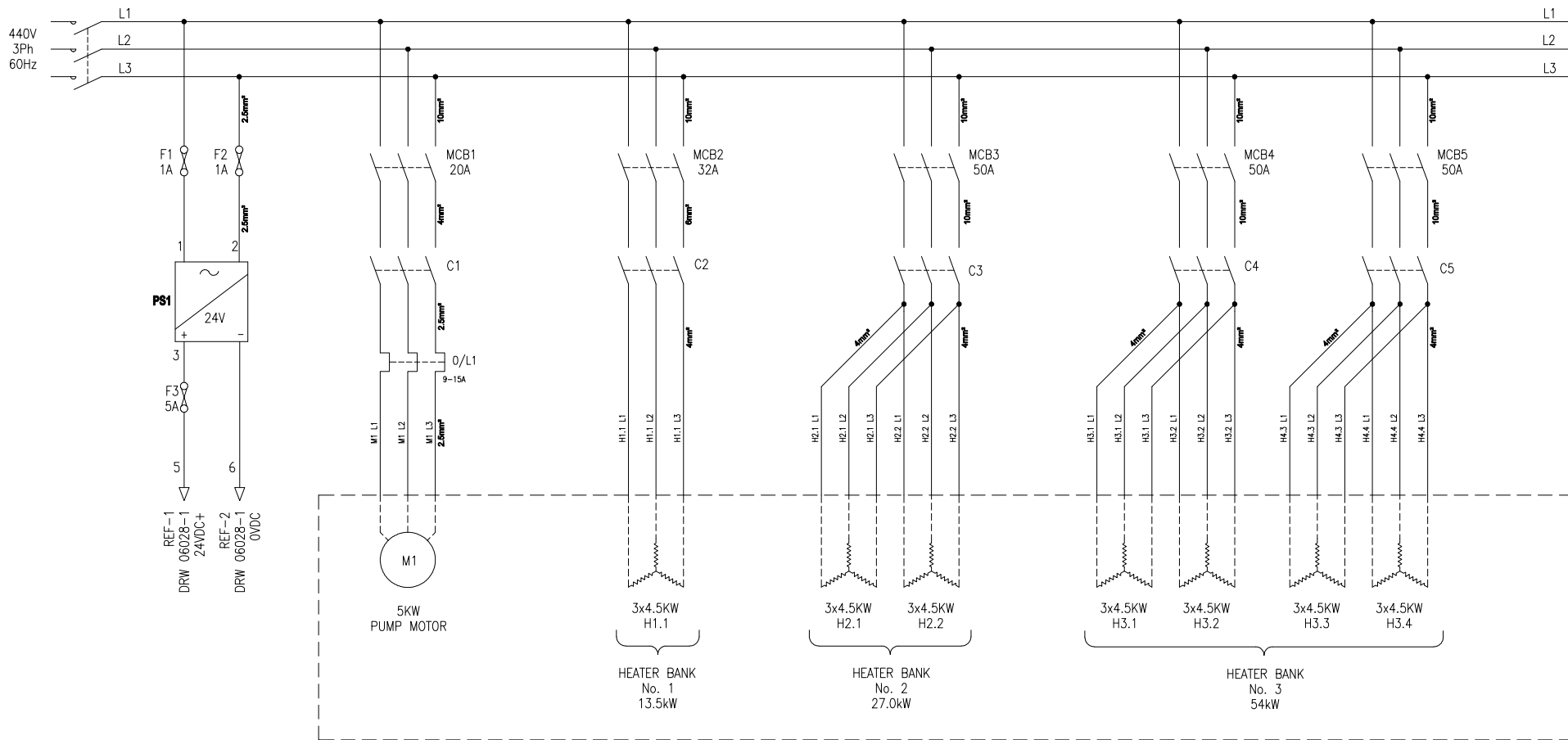

THIRD ANGLE PROJECTION		MATERIAL:		FINISH:		MASS: (kg)		COPYRIGHT EXISTS IN THIS DRAWING AND ALL INFORMATION THEREIN IN TERMS OF COPYRIGHT LAW. THIS DRAWING IS ONLY TO BE USED FOR THE PURPOSE FOR WHICH IT WAS SUPPLIED TO THE SECOND PARTY AND MAY NOT BE REPRODUCED IN WHOLE OR IN PART BY ANY MEANS WHATSOEVER AND ITS CONTENTS MAY NOT BE DISCLOSED TO ANY OTHER PARTY WITHOUT THE CONSENT OF DIVEX (PTY) LTD. NO LICENCE OR RIGHTS TO MANUFACTURE THE EQUIPMENT IS GIVEN OR IMPLIED.		ITEM	QTY	DESCRIPTION	MATERIAL/REMARKS	DRAWING No/PART No				
		-																
R01 AMENDED AS PER ECN-CT00276		---	R.C.	18/06/10	D.H.	18/06/10	G.D.	18/06/10	N.M.	18/06/10								
R00 FIRST ISSUE		---	R.C.	12/08/09	D.H.	12/08/09	G.D.	28/08/09	R.F.	01/09/09								
REV	DESCRIPTION OF REVISION	ECN	DRAWN	DATE	DRAFTING CHECK BY	DATE	ENGINEER CHECK BY	DATE	APPROVAL BY	DATE								
											OVER-TO	±	±	±	SCALE	PRODUCT/PROJECT	TITLE	
											0-6	0.1	0.2	0.5	N.T.S.	MHE-02	MHE-02 ELECTRICAL SCHEMATIC HEATER CIRCUIT	
											6-30	0.2	0.5	1.0			PART No. 06028-2	
											30-100	0.5	0.8	1.5	ALL DIMENSIONS IN MM (UOS) DO NOT SCALE			
											100-300	0.5	1.2	2.0	ALL DIMENSIONS BEFORE PLATING (UOS)			
											300-1000	0.8	2.0	5.0	CAD REF/DRG No. 06028-2		SHT 1 OF 1	
											1000-3000	1.2	3.0	5.0	REMOVE SHARP EDGES & BURRS			
											3000-PLUS	2.0	4.0	8.0				
											ANGLE	0.25°	0.5°	1°				

DIVEX (PTY) LTD
 CAPE TOWN, SOUTH AFRICA
 P.O. BOX 36541, CHEMPET, 7442
 TEL : +27 (0)21 551-2233
 FAX : +27 (0)21 552-3547
 www.divexglobal.com

A3

APPENDIX E PIPING AND FLOW SCHEMATIC

APPENDIX F RKC CB100 DIGITAL CONTROLLER MANUAL

Digital Controller
CB100/CB400/CB500/CB700/CB900
INSTRUCTION MANUAL

IMCB34-E1

Thank you for purchasing this RKC product. In order to achieve maximum performance and ensure proper operation of your new instrument, carefully read all the instructions in this manual. Please place the manual in a convenient location for easy reference.



WARNING

- To prevent injury to persons, damage to instrument and equipment, a suitable external protection device shall be required.
- All wiring must be completed before power is turned on to prevent electric shock, fire or damage to instrument and equipment.
- This instrument must be used in accordance with the specifications to prevent fire or damage to instrument and equipment.
- This instrument is not intended for use in locations subject to flammable or explosive gases.
- Do not touch high-voltage connections such as power supply terminals, etc. to avoid electric shock.
- RKC is not responsible if this instrument is repaired, modified or disassembled by other than factory-approved personnel. Malfunction can occur and warranty is void under these conditions.

CAUTION

- This product is intended for use with industrial machines, test and measuring equipment. (It is not designed for use with medical equipment and nuclear energy.)
- This is a Class A instrument. In a domestic environment, this instrument may cause radio interference, in which case the user may be required to take additional measures.
- This instrument is protected from electric shock by reinforced insulation. Provide reinforced insulation between the wire for the input signal and the wires for instrument power supply, source of power and loads.
- Be sure to provide an appropriate surge control circuit respectively for the following:
 - If input/output or signal lines within the building are longer than 30 meters.
 - If input/output or signal lines leave the building, regardless the length.
- This instrument is designed for installation in an enclosed instrumentation panel. All high-voltage connections such as power supply terminals must be enclosed in the instrumentation panel to avoid electric shock by operating personnel.
- All precautions described in this manual should be taken to avoid damage to the instrument or equipment.
- All wiring must be in accordance with local codes and regulations.
- All wiring must be completed before power is turned on to prevent electric shock, instrument failure, or incorrect action. The power must be turned off before repairing work for input break and output failure including replacement of sensor, contactor or SSR, and all wiring must be completed before power is turned on again.
- To prevent instrument damage as a result of failure, protect the power line and the input/output lines from high currents with a suitable overcurrent protection device with adequate breaking capacity such as a fuse, circuit breaker, etc.
- Prevent metal fragments or lead wire scraps from falling inside instrument case to avoid electric shock, fire or malfunction.
- Tighten each terminal screw to the specified torque found in the manual to avoid electric shock, fire or malfunction.
- For proper operation of this instrument, provide adequate ventilation for heat dispensation.
- Do not connect wires to unused terminals as this will interfere with proper operation of the instrument.
- Turn off the power supply before cleaning the instrument.
- Do not use a volatile solvent such as paint thinner to clean the instrument. Deformation or discoloration will occur. Use a soft, dry cloth to remove stains from the instrument.
- To avoid damage to instrument display, do not rub with an abrasive material or push front panel with a hard object.
- When high alarm with hold action is used for Alarm function, alarm does not turn on while hold action is in operation. Take measures to prevent overheating which may occur if the control device fails.

NOTICE

- This manual assumes that the reader has a fundamental knowledge of the principles of electricity, process control, computer technology and communications.
- The figures, diagrams and numeric values used in this manual are only for purpose of illustration.
- RKC is not responsible for any damage or injury that is caused as a result of using this instrument, instrument failure or indirect damage.
- RKC is not responsible for any damage and/or injury resulting from the use of instruments made by imitating this instrument.
- Periodic maintenance is required for safe and proper operation of this instrument. Some components have a limited service life, or characteristics that change over time.
- Every effort has been made to ensure accuracy of all information contained herein. RKC makes no warranty expressed or implied, with respect to the accuracy of the information. The information in this manual is subject to change without prior notice.
- No portion of this document may be reprinted, modified, copied, transmitted, digitized, stored, processed or retrieved through any mechanical, electronic, optical or other means without prior written approval from RKC.

1. PRODUCT CHECK

CB100						*					/Y
CB400	□	□	□	□	□	□	□	□	□	□	□
CB500	(1)	(2)	(3)	(4)	(5)	(6)	(7)	(8)	(9)	(10)	(11)
CB700											
CB900											

(1) Control action

- F: PID action with autotuning (Reverse action)
- D: PID action with autotuning (Direct action)
- W: Heat/Cool PID action with autotuning (Water cooling)¹
- A: Heat/Cool PID action with autotuning (Air cooling)¹

(2) Input type, (3) Range code: Refer to "9. INPUT RANGE TABLE."

(4) First control output [OUT1] (Heat-side)

- M: Relay contact
- T: Triac
- V: Voltage pulse
- 8: Current (4 to 20 mA DC)
- G: Trigger for triac driving

(5) Second control output [OUT2] (Cool-side)

- No symbol: When control action is F or D.
- M: Relay contact
- T: Triac
- V: Voltage pulse
- 8: Current (4 to 20 mA DC)

(6) Alarm 1 [ALM1], (7) Alarm 2 [ALM2]

- N: No alarm
- A: Deviation high alarm
- B: Deviation low alarm
- C: Deviation high/low alarm
- D: Band alarm
- E: Deviation high alarm with hold action
- F: Deviation low alarm with hold action
- G: Deviation high/low alarm with hold action
- H: Process high alarm
- J: Process low alarm
- K: Process high alarm with hold action
- L: Process low alarm with hold action
- P: Heater break alarm (HBA) [CTL-6]²
- S: Heater break alarm (HBA) [CTL-12]²
- R: Control loop break alarm (LBA)³
- V: SV high alarm
- W: SV low alarm

(8) Communication function

- N: No communication function
- 5: RS-485 (2-wire system)

(9) Waterproof/Dustproof

- N: No Waterproof/Dustproof
- 1: Waterproof/Dustproof

(10) Case color

- N: White
- A: Black

(11) Version symbol

- No code: For Japanese domestic market
- /Y: For International market

¹ No self-tuning function is provided in the W or A control action type.

² Heater break alarm (HBA) cannot be specified in case of ALM1. Also, it isn't possible to specify when control output is current output.

³ As control loop break alarm (LBA), only either the ALM1 or ALM2 is selected.



Check that power supply voltage is also the same as that specified when ordering.

<Accessories>

- Mounting frame (CB100): 1 (KCA100-526)
- Mounting brackets (CB400/500/700/900): 2 *(KCA400-532)
- Instruction manual (IMCB34-E1): 1
- * For CB900 waterproof/dustproof (optional): 4 pieces

2. MOUNTING

2.1 Mounting Cautions

- (1) This instrument is intended to be used under the following environmental conditions. (IEC61010-1)
 [OVERVOLTAGE CATEGORY II, POLLUTION DEGREE 2]
- (2) Use this instrument within the following environment conditions:
 - Allowable ambient temperature: 0 to 50 °C
 - Allowable ambient humidity: 5 to 95 % RH (Absolute humidity: MAX. W. C 29.3 g/m³ dry air at 101.3 kPa)
 - Installation environment conditions: Indoor use, Altitude up to 2000 m
- (3) Avoid the following conditions when selecting the mounting location:
 - Rapid changes in ambient temperature which may cause condensation.
 - Corrosive or inflammable gases.
 - Direct vibration or shock to the mainframe.
 - Water, oil, chemicals, vapor or steam splashes.
 - Excessive dust, salt or iron particles.
 - Excessive induction noise, static electricity, magnetic fields or noise.
 - Direct air flow from an air conditioner.
 - Exposure to direct sunlight.
 - Excessive heat accumulation.
- (4) Mount this instrument in the panel considering the following conditions:
 - Provide adequate ventilation space so that heat does not build up.
 - Do not mount this instrument directly above equipment that generates large amount of heat (heaters, transformers, semi-conductor functional devices, large-wattage resistors.)
 - If the ambient temperature rises above 50 °C, cool this instrument with a forced air fan, cooler, etc. Cooled air should not blow directly on this instrument.
 - In order to improve safety and the immunity to withstand noise, mount this instrument as far away as possible from high voltage equipment, power lines, and rotating machinery.
 - High voltage equipment: Do not mount within the same panel.
 - Power lines: Separate at least 200 mm.
 - Rotating machinery: Separate as far as possible.
 - For correct functioning mount this instrument in a horizontal position.
- (5) In case this instrument is connected to a supply by means of a permanent connection, a switch or circuit-breaker shall be included in the installation. This shall be in close proximity to the equipment and within easy reach of the operator. It shall be marked as the disconnecting device for the equipment.

2.2 Dimensions

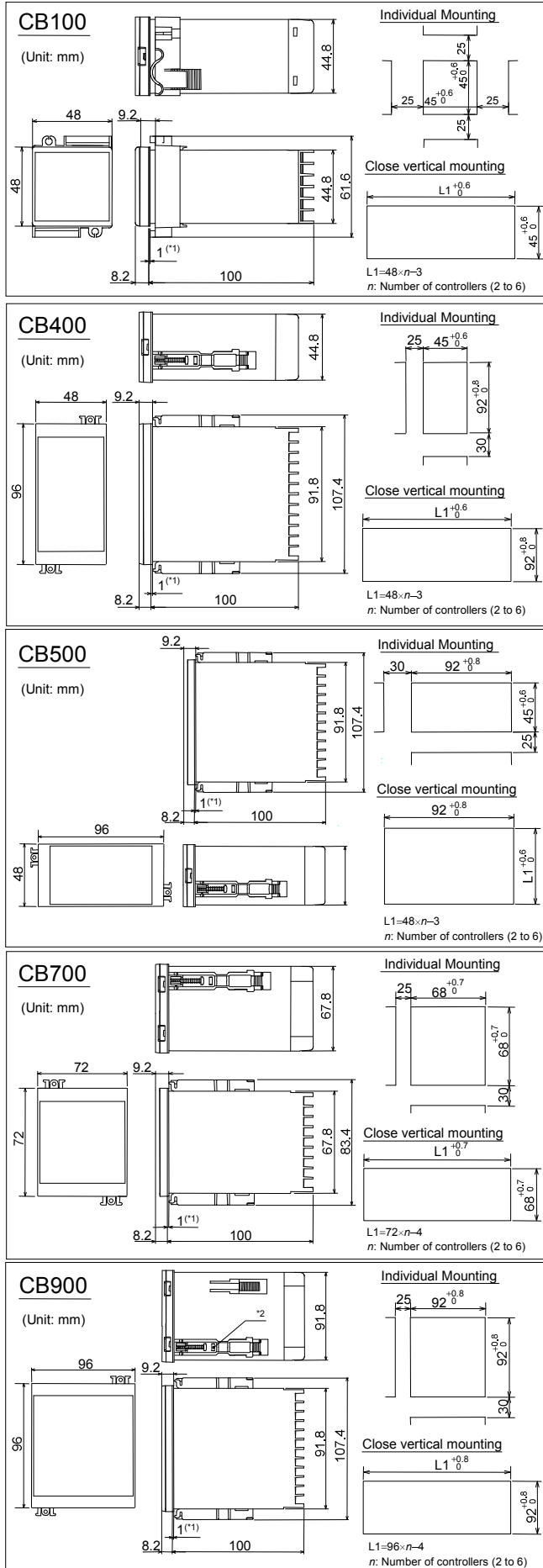

*1 Rubber (optional)

*2 Up to four mounting brackets can be used.

• For mounting of the instrument, panel thickness must be between 1 to 10 mm. (When mounting multiple instruments close together, the panel strength should be checked to ensure proper support.)

• Waterproof and Dustproof are not effective when instruments are closely spaced.

2.3 Mounting Procedures

■ CB100

<Mounting Procedures>

1. Prepare the panel cutout as specified in 2.2 Dimensions.
2. Insert the instrument through the panel cutout.
3. Insert the mounting frame into the mounting groove of the instrument.
4. Push the mounting frame forward until the frame is firmly secured to the panel. (Fig.1)
5. Fix the instrument to the panel by using the two screws. (Fig.2)

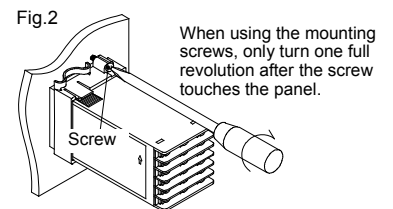
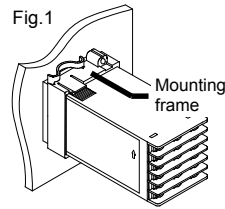

When using the mounting screws, only turn one full revolution after the screw touches the panel.



The optional waterproof/dustproof on the front of the instrument conforms to IP66 when mounted on the panel. For effective waterproof/dustproof, the gasket must be securely placed between instrument and panel without any gap. If the gasket is damaged, please contact RKC sales office or the agent.

<Removal Procedures>

1. Turn the power OFF.
2. Remove the wiring.
3. Loosen the screw of the mounting frame.
4. Remove the mounting frame from the case. (Fig.3)

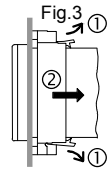

■ CB400/500/700/900

<Mounting Procedures>

1. Prepare the panel cutout as specified in 2.2 Dimensions.
2. Insert the instrument through the panel cutout.
3. Insert the mounting bracket into the mounting groove of the instrument. Do not push the mounting bracket forward. (Fig. 1)
4. Secure the bracket to the instrument by tightening the screw. Take care to refrain from moving the bracket forward.
5. Only turn about one full revolution after the screw touches the panel. (Fig. 2)



If the screw has been rotated too tight, the screw may turn idle. In such a case, loosen the screw once and tighten it again until the instrument is firmly fixed.

6. The other mounting bracket should be installed in the same way as described in 3. to 5.

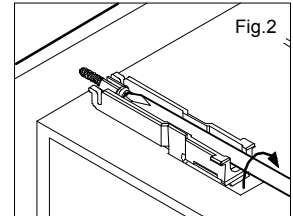
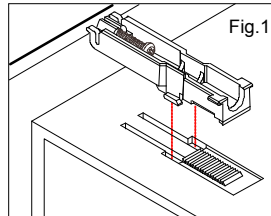

When the instrument is mounted, always secure with two mounting brackets so that upper and lower mounting brackets are positioned diagonally.



The optional waterproof/dustproof (CB900: mounting bracket 4 pieces) on the front of the instrument conforms to IP65 when mounted on the panel. For effective waterproof/dustproof, the gasket must be securely placed between instrument and panel without any gap. If gasket is damaged, please contact RKC sales office or the agent.

<Removal Procedures>

1. Turn the power OFF.
2. Remove the wiring.
3. Loosen the screw of the mounting bracket.
4. Hold the mounting bracket by the edge (①) and tilt it (②) to remove from the case. (Fig. 3)
5. The other mounting bracket should be removed in the same way as described in 3. and 4.
6. Pull out the instrument from the mounting cutout while holding the front panel frame of this instrument. (Fig. 4)

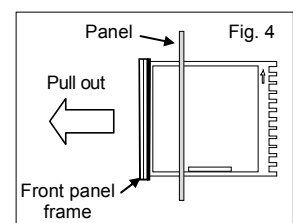
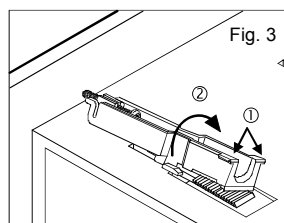

3. WIRING

3.1 Wiring Cautions

- For thermocouple input, use the appropriate compensation wire.
- For RTD input, use low resistance lead wire with no difference in resistance between the three lead wires.
- To avoid noise induction, keep input signal wire away from instrument power line, load lines and power lines of other electric equipment.
- For the current input specification, an external resistor (250 Ω ±0.02 %, 0.25 W or more, ±10 ppm/°C) must be connected between the input terminals. For external resistor (shunt resistor), use the KD100-55: sold separately (RKC product). If this resistor is installed, close horizontal mounting is not possible.
- Signal connected to Voltage input and Current input shall be low voltage defined as "SELV" circuit per IEC 60950-1.
- If there is electrical noise in the vicinity of the instrument that could affect operation, use a noise filter.
 - Shorten the distance between the twisted power supply wire pitches to achieve the most effective noise reduction.
 - Always install the noise filter on a grounded panel. Minimize the wiring distance between the noise filter output and the instrument power supply terminals to achieve the most effective noise reduction.
 - Do not connect fuses or switches to the noise filter output wiring as this will reduce the effectiveness of the noise filter.
- Allow approximately 4 seconds for contact output when the instrument is turned on. Use a delay relay when the output line is used for an external interlock circuit.
- Power supply wiring must be twisted and have a low voltage drop.
- This instrument with 24 V power supply is not provided with an overcurrent protection device. For safety install an overcurrent protection device (such as fuse) with adequate breaking capacity close to the instrument.
 - Fuse type: Time-lag fuse (Approved fuse according IEC60127-2 and/or UL248-14)
 - Fuse rating: Rated current: 0.5 A
- For an instrument with 24 V power supply input, supply power from "SELV" circuit defined as IEC 60950-1.
- A suitable power supply should be considered in end-use equipment. The power supply must be in compliance with a limited-energy circuits (maximum available current of 8 A).
- Use the solderless terminal appropriate to the screw size.
 - Screw size: M3 x 6
 - Recommended tightening torque: 0.4 N·m [4 kgf·cm]
 - Specified solderless terminals: With isolation
 - Applicable wire: Solid/twisted wire of 0.25 to 1.65 mm²
- Make sure that during field wiring parts of conductors can not come into contact with adjacent conductive parts.

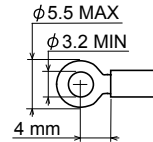
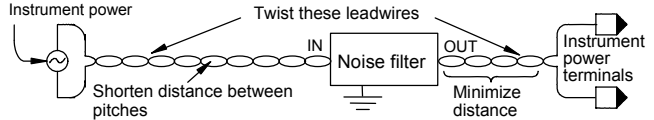

3.2 Terminal Configuration

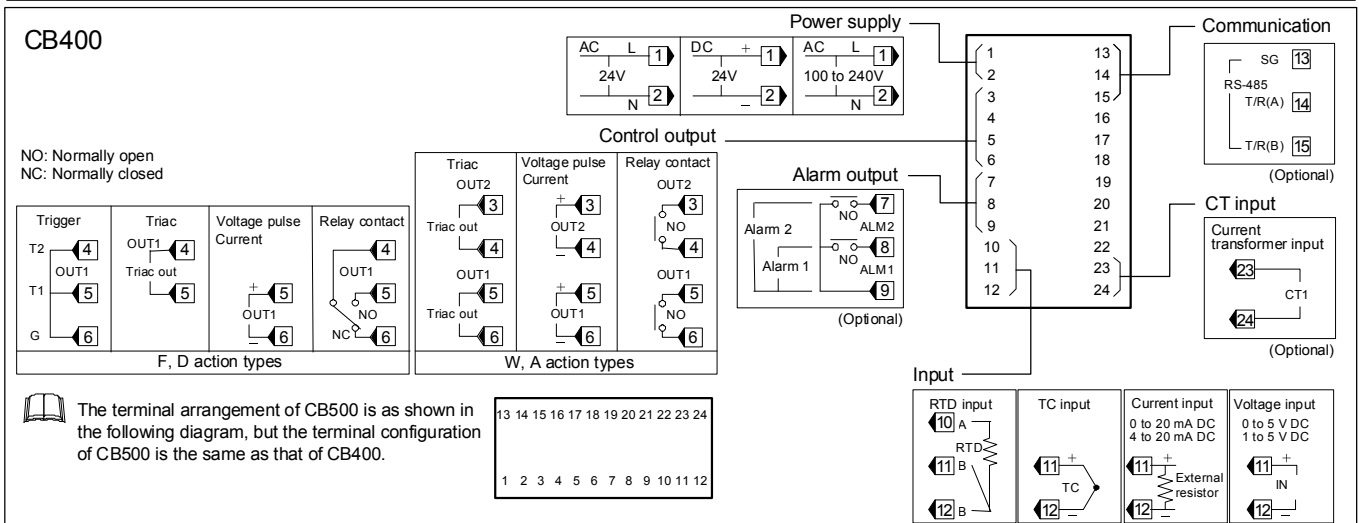
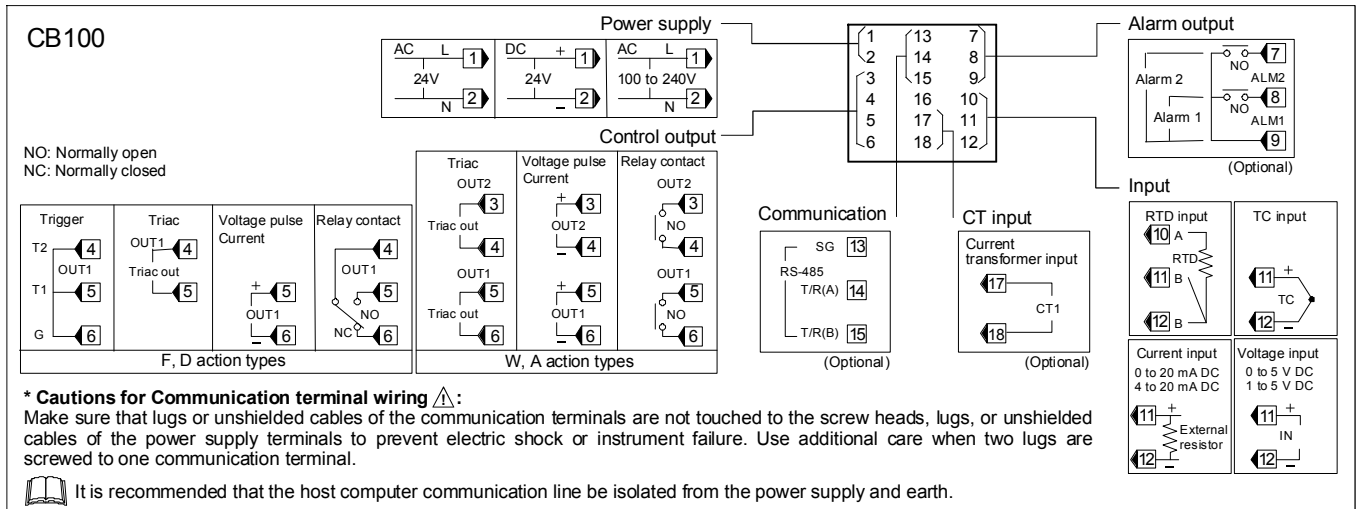

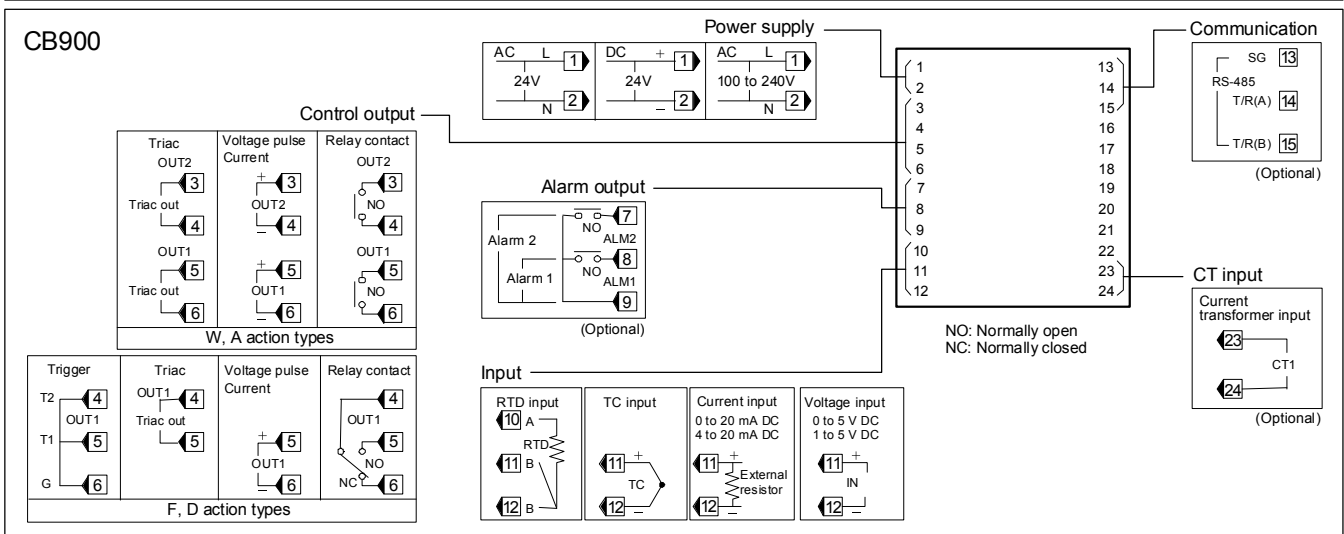
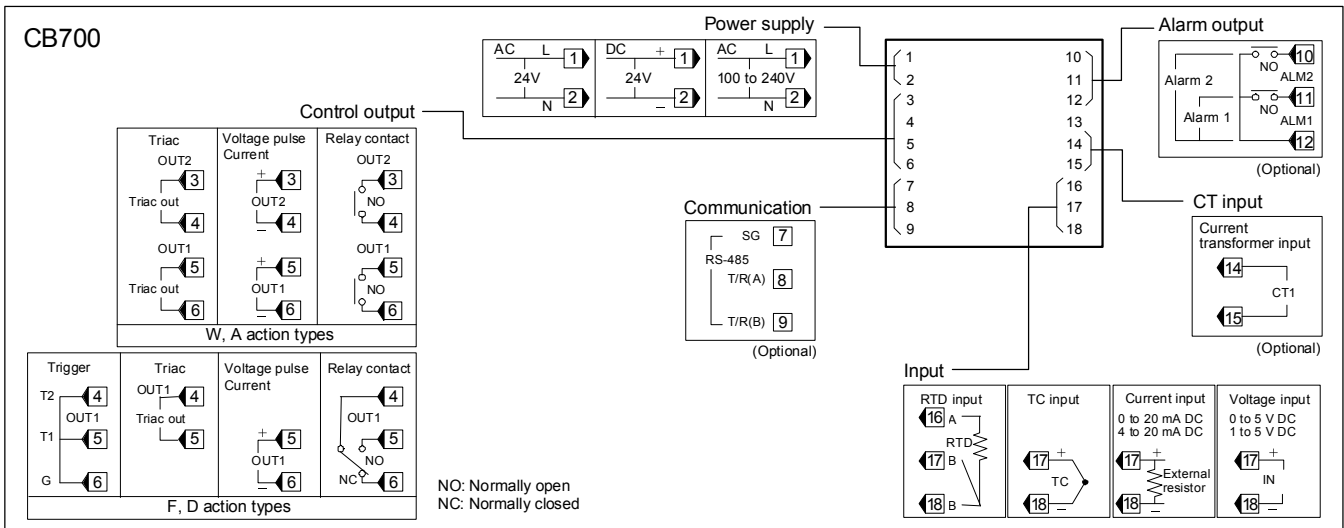

Specifications

Input:

Input type:

Thermocouple: K, J, R, S, B, E, T, N, PLII, W5Re/W26Re, U, L
 Input impedance: Approx. 1 MΩ

RTD: Pt100, JPt100

Voltage: 0 to 5 V DC, 1 to 5 V DC, 0 to 10 V DC (Z-1010)

Current: 0 to 20 mA DC, 4 to 20 mA DC

Sampling cycle: 0.5 seconds

Input range: Refer to **Input range table**

Control method:

PID control
 ON/OFF, P, PI, or PD actions is available

Control output:

Relay contact output:

250 V AC, 3A (Resistive load)
 Electrical life: 300,000 times or more (Rated load)

Voltage pulse output:

0/12 V DC (Load resistance 600 Ω or more)

Current output: 4 to 20 mA DC (Load resistance 600 Ω or less)

Trigger output for triac driving:

Zero cross method for medium capacity triac driving (100 A or less)
 Load voltage used: 100 V AC line, 200 V AC line
 Load used: Resistive load

Triac output:

Output method:
 AC output (Zero-cross method)
 Allowable load current:
 0.5 A (Ambient temperature: 40 °C or less)
 Load voltage: 75 to 250 V AC
 Minimum load current: 20 mA
 ON voltage:
 1.6 V or less (at maximum load current)

Alarm output:

Relay contact output:

250 V AC, 1A (Resistive load)
 Electrical life: 50,000 times or more (Rated load)

Performance:

Display accuracy (at the ambient temperature 23 °C ± 2 °C):

Thermocouple:

± (0.3 % of display value + 1 digit) or ± 2 °C [4 °F]

Whichever is greater

R, S and B input: 0 to 399 °C [0 to 799 °F]

Accuracy is not guaranteed.

T and U input: -199.9 to -100.0 °C [-199.9 to -158.0 °F]

Accuracy is not guaranteed.

RTD: ± (0.3 % of display value + 1 digit) or ± 0.8 °C [1.6 °F]

Whichever is greater

Voltage/Current:

± (0.3 % of Input span + 1 digit)

Memory backup:

Backed up by Nonvolatile Memory

Number of write times: Approx. 1,000,000 times

Data storage period: Approx. 10 years

Power:

Power supply voltage:

85 to 264 V AC (Power supply voltage range), 50/60 Hz

Rating: 100 to 240 V AC

21.6 to 26.4 V AC (Power supply voltage range), 50/60 Hz

Rating: 24 V AC

21.6 to 26.4 V DC (Power supply voltage range)

Rating: 24 V DC

Power consumption:

7 VA max. (at 100 V AC)

10 VA max. (at 240 V AC)

5 VA max. (at 24 V AC)

160 mA max. (at 24 V DC)

Weight:

CB100: Approx. 170 g

CB700: Approx. 290 g

CB400/CB500: Approx. 250 g

CB900: Approx. 340 g

4. PARTS DESCRIPTION

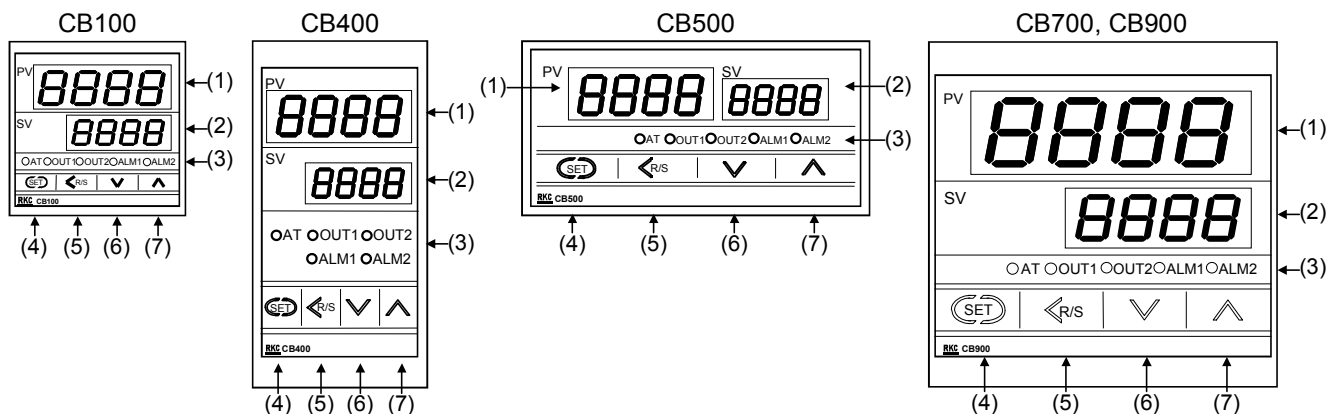

(1) Measured value (PV) display [Green]
Displays PV or various parameter symbols.

(2) Set value (SV) display [Orange]
Displays SV or various parameter set values (or CT input value).

(3) Indication lamps
Alarm output lamps (ALM1, ALM2) [Red]
ALM1: Lights when alarm 1 output is turned on.
ALM2: Lights when alarm 2 output is turned on.

Autotuning (AT) lamp [Green]
Flashes when autotuning is activated. (After autotuning is completed: AT lamp will go out)

Control output lamps (OUT1, OUT2) [Green]
OUT1: Lights when control output is turned on.*
OUT2: Lights when cool-side control output is turned on.*

* Lamp indication becomes as follows for current output.
For an output of less than 0 %: Extinguished
For an output of more than 100 %: Lit
For an output of more than 0 % but less than 100 %: Dimly lit.

(4) SET (Set key)
Used for parameter calling up and set value registration.

(5) <R/S (Shift & R/S key)
Shift digits when settings are changed. Select the RUN/STOP function.

(6) V (DOWN key)
Decrease numerals.

(7) ^ (UP key)
Increase numerals.

To avoid damage to the instrument, never use a sharp object to press keys.

5. SETTING

5.1 Operation Menu

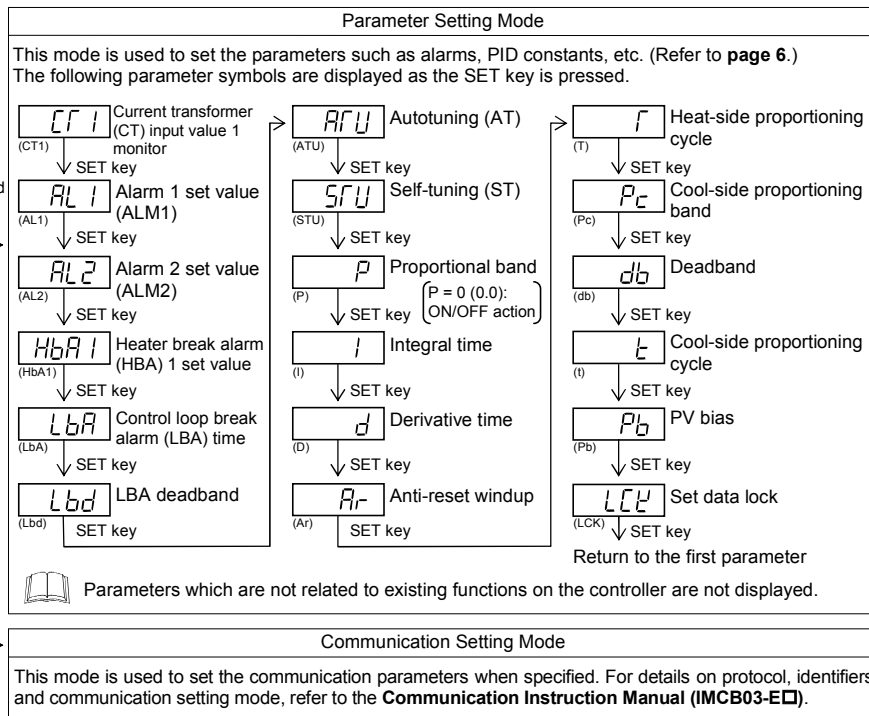
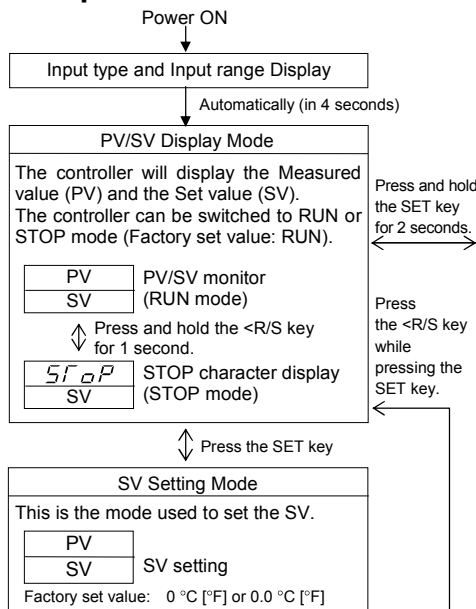

Display returns to the PV/SV display mode if no key operation is performed within 1 minute.

Input type and input range display

This instrument immediately confirms the input type symbol and input range following power ON.
Example: When sensor type of input is K thermocouple.

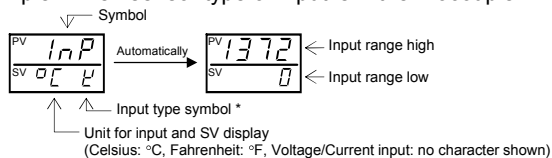

* Input Type Symbol Table

Symbol	K	J	R	S	B	E	T	N	PL	II	P	U	U	L	U ^P	P ^r	U
Input type	Thermocouple (TC)										RTD		Voltage (Current)				
											JPt 100	Pt 100					
											WSRe/W26Re (*)						

(*): This input type is not displayed in the Z-1021 specification.

5.2 Parameter List



Parameter symbols which are not related to existing functions on the controller are not displayed.

Symbol	Name	Setting range	Description	Factory set value
<i>CT1</i>	Current transformer (CT) input value 1 monitor	0.0 to 100.0 A [Display only]	Display input value from the current transformer. [Displayed only when the instrument has the Heater break alarm (HBA)]	
<i>AL1</i>	Alarm 1 set value (ALM1)	TC/RTD inputs: Deviation alarm, Process alarm, SV alarm: -1999 to +9999 °C [°F] or -199.9 to +999.9 °C [°F]	Set the alarm 1 set value and alarm 2 set value. For the alarm action type, refer to page 10 and 11.	TC/RTD inputs: 50 (50.0) Voltage/Current inputs: 5.0
<i>AL2</i>	Alarm 2 set value (ALM2)	Voltage/Current inputs: Deviation alarm: -Input span to +Input span (Within 9999) Process alarm, SV alarm: Same as input range	Alarm differential gap: TC/RTD inputs: 2 or 2.0 °C [°F] Voltage/Current inputs: 0.2% of Input span	
<i>HBA1</i>	Heater break alarm (HBA) 1 set value ¹	0.0 to 100.0 A	Alarm value is set by referring to input value from the Current transformer (CT). Used only for single-phase.	0.0
<i>LBA</i>	Control loop break alarm (LBA) time ²	0.1 to 200.0 minutes	Set control loop break alarm (LBA) set value.	8.0
<i>Lbd</i>	LBA deadband ³	TC/RTD inputs: 0 to 9999 °C [°F] Voltage/Current inputs: 0 to 100 % of Input span	Set the area of not outputting LBA. No LBA deadband functions with 0 set. Differential gap : TC/RTD inputs: 0.8 °C [°F] Voltage/Current inputs: 0.8 % of Input span	0
<i>ATU</i>	Autotuning (AT)	0: AT end or cancel 1: AT start or execution	Turns the Autotuning ON/OFF.	0
<i>STU</i>	Self-tuning (ST)	0: Self-tuning OFF 1: Self-tuning ON	Turns the Self-tuning ON/OFF.	0
<i>P</i>	Proportional band	TC/RTD inputs: 1 (0.1) to Input span or 9999 (999.9) °C [°F] Voltage/Current inputs: 0.1 to 100.0 % of Input span 0 (0.0): ON/OFF action	Set when PI, PD or PID control is performed. Heat/Cool PID action: Proportional band setting on the heat-side. ON/OFF action differential gap: TC/RTD inputs: 2 (0.2) °C [°F] Voltage/Current inputs: 0.2 % of Input span	TC/RTD inputs: 30 (30.0) Voltage/Current inputs: 3.0
<i>I</i>	Integral time	1 to 3600 seconds (0 second: PD action)	Set the time of integral action to eliminate the offset occurring in proportional control.	240
<i>d</i>	Derivative time	1 to 3600 seconds (0 second: PI action)	Set the time of derivative action to improve control stability by preparing for output changes.	60
<i>Ar</i>	Anti-reset windup (ARW)	1 to 100 % of heat-side proportional band (0 %: Integral action OFF)	Overshooting and undershooting are restricted by the integral effect.	100
<i>r</i>	Heat-side proportioning cycle	1 to 100 seconds (Not displayed if the control output is current output.)	Set control output cycle. Heat/Cool PID action: Heat-side proportioning cycle	Relay contact output: 20 Voltage pulse output/ Trigger output for triac driving/Triac output: 2
<i>Pc</i>	Cool-side proportional band	1 to 1000 % of heat-side proportional band.	Set cool-side proportional band when Heat/Cool PID action.	100
<i>db</i>	Deadband	TC/RTD inputs: -10 to +10 °C [°F] or -10.0 to +10.0 °C [°F] Voltage/Current inputs: -10.0 to +10.0 % of Input span	Set control action deadband between heat-side and cool-side proportional bands. Minus (-) setting results in overlap.	0 or 0.0
<i>L</i>	Cool-side proportioning cycle	1 to 100 seconds (Not displayed if the control output is current output.)	Set control cool-side output cycle for Heat/Cool PID action.	Relay contact output: 20 Voltage pulse output/ Triac output: 2
<i>Pb</i>	PV bias	TC/RTD inputs: -1999 to +9999 °C [°F] or -199.9 to +999.9 °C [°F] Voltage/Current inputs: -Input span to +Input span	Sensor correction is made by adding bias value to Measured value (PV).	0 or 0.0
<i>LCK</i>	Set data lock (LCK)	 Parameters other than SV and Alarms Alarms: 0: Unlock 1: Lock SV: 0: Unlock 1: Lock Initialization mode: 0: Lock 1: Unlock	Performs set data change enable/disable.	0000

1 Heater break alarm (HBA) function

The HBA function monitors the current flowing through the load by a dedicated Current transformer (CT), compares the measured value with the HBA set value, and detects a fault in the heating circuit.

Low or No current flow (Heater break, malfunction of the control device, etc.):

When the control output is ON and the current transformer input value is equal to or less than the heater break determination point for the preset number of consecutive sampling cycle, an alarm is activated.

Over current or short-circuit:

When the control output is OFF and the current transformer input value is equal to or greater than the heater break determination point for the preset number of consecutive sampling cycle, an alarm is activated.



Precaution for HBA setting:

- Displayed only for when HBA is selected as Alarm 2.
- HBA is not available on a current output.
- Set the set value to approximately 85 % of the maximum reading of the CT input.
- Set the set value to a slightly smaller value to prevent a false alarm if the power supply may become unstable.
- When more than one heater is connected in parallel, it may be necessary to increase the HBA set value to detect a single heater failure.
- When the current transformer is not connected, the HBA is turned on.

2 Control loop break alarm (LBA) function

The LBA function is used to detect a load (heater) break or a failure in the external actuator (power controller, magnet relay, etc.), or a failure in the control loop caused by an input (sensor) break. The LBA function is activated when control output reaches 0 % (low limit with output limit function) or 100 % (high limit with output limit function). LBA monitors variation of the measured value (PV) for the length of LBA time. When the LBA time has elapsed and the PV is still within the alarm determination range, the LBA will be ON.



Precaution for LBA setting:

- Displayed only for when LBA is selected as Alarm 1 or Alarm 2.
- No LBA function can be used at Heat/Cool PID control action.
- The LBA function can not be activated when AT function is turned on.
- The LBA function is activated when control output reaches 0 % or 100 %. The time required for the LBA output to turn on includes both the time from the initial occurrence of loop failure and the LBA setting time. Recommended setting for LBA is for the set value of the LBA to be twice the value of the Integral time (I).
- If LBA setting time does not match the controlled object requirements, the LBA setting time should be lengthened. If setting time is not correct, the LBA will malfunction by turning on or off at inappropriate times or not turning on at all.

3 LBA deadband function

The LBA may malfunction due to external disturbances. To prevent malfunctioning due to external disturbance, LBA deadband (LBD) sets a neutral zone in which LBA is not activated. When the Measured value (PV) is within the LBD area, LBA will not be activated. If the LBD setting is not correct, the LBA will not work correctly.

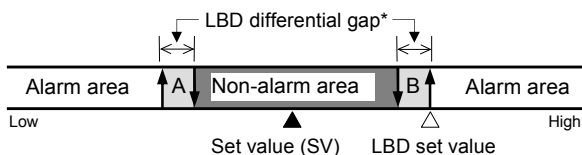

A: During temperature rise: Alarm area B: During temperature rise: Non-alarm area
 During temperature fall: Non-alarm area During temperature fall: Alarm area

* TC and RTD inputs: 0.8 °C [°F] (fixed)
 Voltage/Current inputs: 0.8 % of input span (fixed)

5.3 Changing Parameter Settings

Procedures to change parameter settings are shown below.

To store a new value for the parameter, always press the SET key. The display changes to the next parameter and the new value will be stored.

- A new value will not be stored without pressing SET key after the new value is displayed on the display.
- After a new value has been displayed by using the UP and DOWN keys, the SET key must be pressed within 1 minute, or the new value is not stored and the display will return to the PV/SV monitor screen.

● Change the Set value (SV)

Change the Set value (SV) from 0 °C to 200 °C

1. Select the SV setting mode

Press the SET key at PV/SV monitor screen until SV setting screen is displayed.

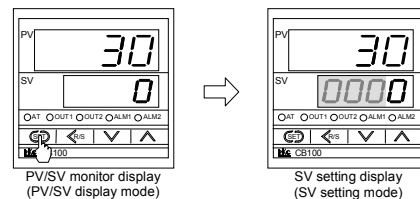

2. Shift the high-lighted digit

Press the <R/S key to high-light the hundreds digit. The high-lighted digit indicates which digit can be set.

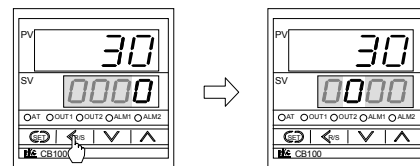

3. Change the set value

Press the UP key to change the number to 2.

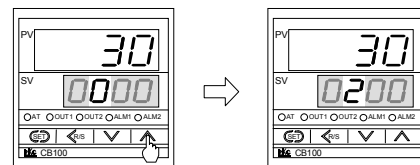

4. Store the set value

Press the SET key to store the new set value. The display returns to the PV/SV monitor screen.

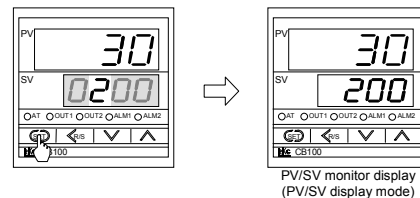

● Change parameters other than the Set value (SV)

The changing procedures are the same as those of example 2 to 4 in the above "● Change the Set value (SV)". Pressing the SET key after the setting end shifts to the next parameter. When no parameter setting is required, return the instrument to the PV/SV display mode.

6. OPERATIONS

CAUTIONS

- All mounting and wiring must be completed before the power is turned on. If the input signal wiring is disconnected or short-circuited (RTD input only), the instrument determines that burnout has occurred.
- Displays:
 - Upscale: Thermocouple input, RTD input (when input break)
 - Downscale: Thermocouple input (specify when ordering), RTD input (when short-circuited), Voltage input (1 to 5 V DC), Current input (4 to 20 mA DC)
 - For the voltage (0 to 5 V DC, 0 to 10 V DC*) or current (0 to 20 mA DC) input, the display becomes indefinite (display of about zero value).
 - * Z-1010 specification
- Outputs:
 - Control output: OFF (Heat/Cool control: the control output on both heat-side and cool-side is turned off)
 - Alarm output: Both of the Alarm 1 and Alarm 2 outputs of this instrument are turned on when burnout occurs regardless of any of the following actions taken (High alarm, low alarm, etc.). In addition, when used for any purposes other than these alarms (event, etc.), specify the Z-124 specification (not to be forcibly turned on).
- A power failure of 20 ms or less will not affect the control action. When a power failure of more than 20 ms occurs, the instrument assumes that the power has been turned off. When power returns, the controller will retain the conditions that existed prior to shut down.
- The alarm hold action is activated when not only the power is turned on, but also the SV is changed.

6.1 Operation Procedures

1. Prior to starting operation, check that the mounting and wiring have been finished, and that the SV and various parameters have been set.
2. A power supply switch is not furnished with this instrument. It is ready to operate as soon as the power is turned on. (Factory set value: RUN).



This instrument holds the conditions that exist just before the power is turned on. For example, if the power is turned off in STOP mode, the instrument starts in STOP mode when the power is turned on again.

■ RUN/STOP

Each time the <R/S> key is pressed for 1 second, RUN/STOP mode changes from RUN to STOP or STOP to RUN. If the instrument is switched to STOP mode, its display, output, etc. become as follows.

- Display: The PV display shows $STOP$ (STOP).
- Output: Control output OFF, Alarm output OFF
- Autotuning: AT canceled (The PID constants are not updated.)

■ RUN/STOP display (Z-1018 specification)

When operation is changed to the STOP mode by RUN/STOP selection, a parameter symbol to indicate the STOP mode is displayed on the SV display. Pressing the SET key with the STOP mode displayed can also check and change the Set value (SV).

6.2 Set Data Lock (LCK) Function

The set data lock restricts parameter setting changes by key operation. This function prevents the operator from making errors during operation. There are 8 set data lock levels. (refer to below)

Set value	Parameters which can be changed
0000	All parameters [Factory set value]
0001	SV, Alarms (ALM1, ALM2)
0010	All parameters except for Alarms (ALM1, ALM2)
0011	SV
0100	All parameters except for SV
0101	Alarms (ALM1, ALM2)
0110	All parameters except for SV and Alarms (ALM1, ALM2)
0111	No parameters (All Locked)

HBA, LBA and LBD can be locked when any of 0001, 0011, 0101 and 0111 is set.



Set data lock can be changed in both RUN and STOP mode.



Parameters protected by Set data lock function are still displayed for monitoring.

6.3 Autotuning (AT) Function

Autotuning (AT) automatically measures, computes and sets the optimum PID and LBA constants. The following conditions are necessary to carry out Autotuning and the conditions which will cause the Autotuning to stop.



Caution for using the Autotuning (AT)

When a temperature change (UP and/or Down) is 1 °C or less per minute during AT, AT may not be finished normally. In that case, adjust the PID values manually. Manual setting of PID values may also be necessary if the set value is around the ambient temperature or is close to the maximum temperature achieved by the load.

■ Requirements for AT start

Start the Autotuning when all following conditions are satisfied:

- Prior to starting the AT function, end all the parameter settings other than PID and LBA.
- Confirm the LCK function has not been engaged.



When the Autotuning is finished, the controller will automatically returns to PID control.

■ Requirements for AT cancellation

The Autotuning is canceled if any of the following conditions exist.

- When the Set value (SV) is changed.
- When the PV bias value is changed.
- When the RUN/STOP mode is changed to the STOP mode.
- When the PV becomes abnormal due to burnout.
- When the power is turned off.
- When power failure longer than 20 ms occurs.
- When the AT does not end in 9 hours after autotuning started.



If the AT is canceled, the controller immediately changes to PID control. The PID values will be the same as before AT was activated.



When AT is completed, the controller immediately changes to PID control. If the control system does not allow the AT cycling process, set each PID constant manually to meet the needs of the application.

6.4 Self-tuning (ST) Function

The ST function is used to automatically calculate and set adaptive PID constants anytime the power is turned on, the SV is changed or the controller detects unstable control conditions.



The ST function should be turned off when the controlled system is affected by rippling that occurs due to periodic external disturbances.



The power to the controlled system must be turned on before the power to the instrument is turned on or SV is changed. This is required when ST function is on.



To activate the ST function, the following parameters must not be set to zero: $P \neq 0$, $I \neq 0$, $D \neq 0$, $ARW \neq 0$.



When Heat/Cool PID action is selected, the ST function can not be activated.



When the AT function is activated, the ST function can not be turned on.



When the ST function is activated, the PID and ARW settings can be monitored, but not changed.

7. INITIAL SETTING

! WARNING

Parameters in the Initialization mode should be set according to the application before setting any parameter related to operation. Once the Parameters in the Initialization mode are set correctly, no further changes need to be made to parameters for the same application under normal conditions. If they are changed unnecessarily, it may result in malfunction or failure of the instrument. RKC will not bear any responsibility for malfunction or failure as a result of improper changes in the Initialization mode.

7.1 Go to Initialization Mode

- Turn on the power to this controller. The instrument goes to the PV/SV display after confirming input type symbol and input range.
- Press and hold the SET key for 2 seconds to go to the Parameter Setting Mode from the PV/SV display.
- Press the SET key until "LCK" (Set data lock display) will be displayed.
- The high-lighted digit indicates which digit can be set. Press <R/S key to high-light the thousands digit. (The section in each image of the controller shows the digits which are not high-lighted.)

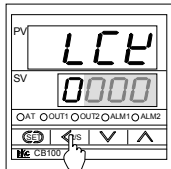

Set data lock function display

- Press the UP key to change 0 to 1.

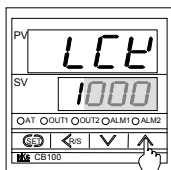

Set value
 0: Initialization mode locked
 1: Initialization mode unlocked

- Press the SET key to store the new set value. The display goes to the next parameter, and the Initialization mode is unlocked.

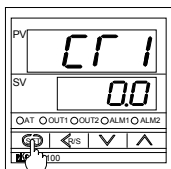

CT1 input value display

The parameter displayed varies on the instrument specification.

- Press the <R/S key for two seconds while pressing the SET key to go to the Initialization mode. When the controller goes to the Initialization mode, "Cod" will be displayed.

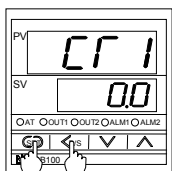

CT1 input value display

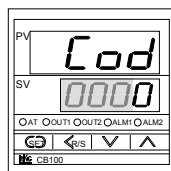

Initialize code selection of initialization mode

Cod 0000	SL1 (Input type selection)	Refer to P. 10
	SL2 (Temperature unit and cooling type selection)	Refer to P. 10
	SL4 (Alarm 1 type selection)	Refer to P. 10
	SL5 (Alarm 2 type selection)	Refer to P. 10
	SL11 (SV alarm type selection)	Refer to P. 11
Cod 0001	SLH (Setting limiter [high])	Refer to P. 11
	SLL (Setting limiter [low])	Refer to P. 11
	PGdP (Decimal point position)	Refer to P. 11

7.2 Exit Initialization Mode

When any parameter setting is changed in the Initialization mode, check all parameter set values in SV setting mode and Parameter setting mode.

- Press the <R/S key for 2 seconds while pressing the SET key from any display in the Initialization mode. The controller goes back to the operation mode and the PV/SV display will be displayed.
- Press and hold the SET key for 2 seconds in the PV/SV display.
- Press the SET key until "LCK" (Set data lock display) will be displayed.
- The high-lighted digit indicates which digit can be set. Press <R/S key to high-light the thousands digit. (The section in each image of the controller shows the digits which are not high-lighted.)
- Press the DOWN key to change 1 to 0.

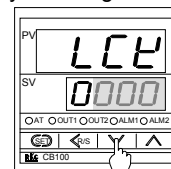

Set data lock function display

- Press the SET key to store the new set value. The display goes to the next parameter, and the Initialization mode is locked.

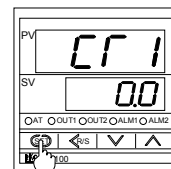

CT1 input value display

The parameter displayed varies on the instrument specification.

7.3 Initial Setting Menu

The "Cod" display will be displayed when the controller goes to the Initialization mode.

Do not change to any parameter in the Initialization mode which is not described in the initial setting menu above. It may result in malfunction or failure of the instrument.

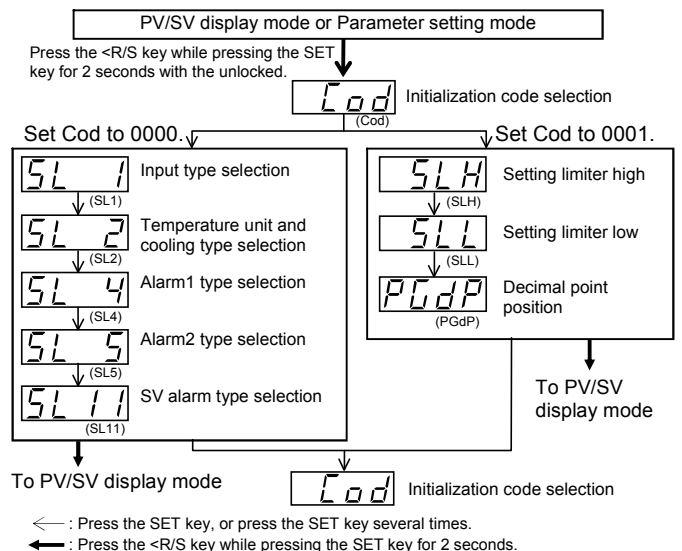

7.4 Input Type Selection (SL1)

When any parameter setting is changed in the Initialization mode, check all parameter set values in SV setting mode and Parameter setting mode.

Factory set value varies depending on the input type.

Set value	Input type	
0000	K	Thermocouple ¹ (TC)
0001	J	
0010	L	
0011	E	
0100	N	
0111	R	
1000	S	
1001	B ⁴	
1010	W5Re/W26Re ⁴	
1011	PL II	
0101	T	
0110	U	
1100	Pt100 Ω (JIS/IEC)	RTD ¹
1101	JPt100 Ω (JIS)	
1110	0 to 5 V DC	Voltage ¹
1110	0 to 10 V DC ²	
1111	1 to 5 V DC	
1110	0 to 20 mA DC	Current ^{1,3}
1111	4 to 20 mA DC	

¹ Any input change in TC&RTD group is possible. Any input change in Voltage & Current group except for 0 to 10 V DC input is possible. No input change between TC&RTD group and Voltage & Current group is possible.

² The input type of Z-1010 specification is fixed to 0 to 10 V DC due to the hardware difference.

³ For the current input specification, a resistor of 250 Ω must be connected between the input terminals.

⁴ W5Re/W26Re and B are not available with Z-1021 specification (Modbus communication).

Change Settings

Example: Change the input type from “K” to “J”

- Set “Cod” to 0000, and press the SET key. The display will go to SL1.

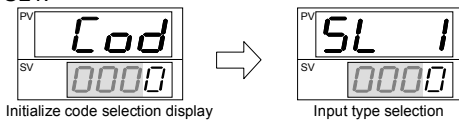

- Press the UP key to change the number to 1.



- Press the SET key to store the new set value. The display goes to the next parameter.

7.5 Temperature Unit and Cooling Type Selection (SL2)

Inappropriate settings may result in malfunction. Control type between Heat Only and Heat/Cool cannot be changed by this parameter.

Factory set value varies depending on the instrument specification.

Set value	Description	
	Temperature unit	Cooling type selection
0000	°C	Air cooling (A type) or Heat only type (F, D type)
0001	°F	Air cooling (A type) or Heat only type (F, D type)
0010	°C	Water cooling (W type)
0011	°F	Water cooling (W type)

Change Settings

Example: Change the temperature unit of the Heat only type from “°C (0000)” to “°F (0001)”

- Press the SET key until SL2 is displayed.
- Press the UP key to change the number to 1.

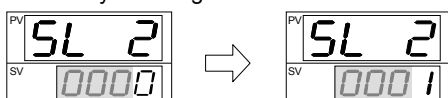

- Press the SET key to store the new set value. The display goes to the next parameter.

7.6 Alarm 1 [ALM1] Type Selection (SL4) Alarm 2 [ALM2] Type Selection (SL5)

If the alarm function is not provided with the instrument when shipped from the factory, no alarm output is available by changing SL4 and/or SL5.

SL4 is set to 0000 in the following cases.

- When the instrument does not have ALM1 output
- When Control loop break alarm (LBA) is provided and assigned to ALM1
- When the SV alarm is provided and assigned to ALM1

SL5 is set to 0000 in the following cases.

- When the instrument does not have ALM2 output
- When Control loop break alarm (LBA) is provided and assigned to ALM2
- When the SV alarm is provided and assigned to ALM2
- When the Heater break alarm (HBA) is provided
- When the instrument has Z-168 specification

Factory set value varies depending on the instrument specification.

Set value	Details of setting
0000	No alarm
0001	Deviation high alarm
0101	Deviation low alarm
0010	Deviation high/low alarm
0110	Band alarm
0011	Process high alarm
0111	Process low alarm
1001	Deviation high alarm with hold action *
1101	Deviation low alarm with hold action *
1010	Deviation high/low alarm with hold action *
1011	Process high alarm with hold action *
1111	Process low alarm with hold action *

* Hold action:

When Hold action is ON, the alarm action is suppressed at start-up or the control set value change until the measured value enters the non-alarm range.

Alarm action type

Both of the Alarm 1 and Alarm 2 outputs of this instrument are turned on when burnout occurs regardless of any of the following actions taken (high alarm, low alarm, etc.). In addition, when used for any purposes other than these alarms (event, etc.), specify the Z-124 specification (not to be forcibly turned on).

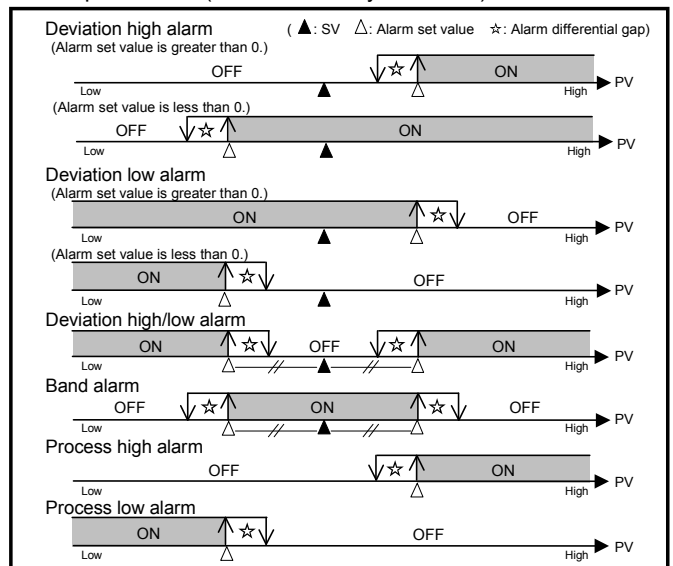

Change Settings

Example: Change the ALM1 type from “Deviation high alarm (0001)” to “Deviation low alarm (0101)”

- Press the SET key three times at SL1 until SL4 is displayed.
- Press the <R/S key to high-light the hundreds digit.
- Press the UP key to change the number to 1.

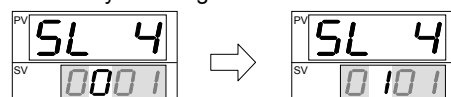

- Press the SET key to store the new set value. The display goes to the next parameter.

7.7 SV Alarm Type Selection (SL11)

For ALM1 setting, the first digit from the right is set to "0" in the following cases.

- When the instrument does not have ALM1 output.
- When the ALM1 output is used for Process/Deviation/Band alarm or Control loop break alarm (LBA).

For ALM2 setting, the third digit from the right is set to "0" in the following cases.

- When the instrument does not have ALM2 output.
- When the ALM1 output is used for Process/Deviation/Band alarm, Heater break alarm (HBA) or Control loop break alarm (LBA).
- When Z-168 is specified.

To make SV alarm setting effective, set SL4 to "0000" when using ALM1 for SV alarm, or set SL5 to "0000" when using ALM2 for SV alarm. SL4 and SL5 have priority to SL11 setting.

Factory set value varies depending on the instrument specification.

Alarm	Details of setting		
Alarm 1 [ALM1]	0	0	SV alarm not provided
	1	1	SV alarm provided
	0	1	SV high alarm
Alarm 2 [ALM2]	0	0	SV alarm not provided
	1	1	SV alarm provided
	0	1	SV high alarm
	1	0	SV low alarm

SV alarm action type

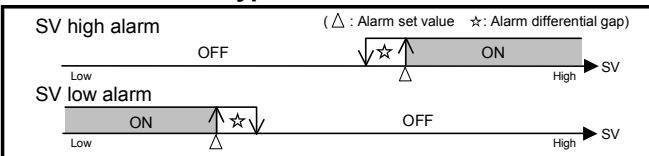

Change Settings

Example: Change the SV alarm type of the ALM1 from "SV high alarm (0001)" to "SV low alarm (0011)"

1. Press the SET key ten times at SL1 until SL11 is displayed.
2. Press the <R/S key to high-light the tens digit. Next, press the UP key to change the number to 1.

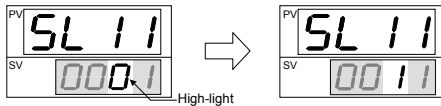

3. Press the SET key to store the new set value. The display goes to the initialize code parameter.

7.8 Setting Limiter High (SLH) Setting Limiter Low (SLL)

For voltage or current input, set scaling within the input range.

Refer to Input range table (P. 12)

Factory set value varies depending on the instrument specification.

Input type	Setting range		
	Setting limiter high	Setting limiter low	
TC	K	SLL to 1372 °C SLL to 2502 °F	0 to SLH °C 0 to SLH °F
	J	SLL to 1200 °C SLL to 2192 °F	0 to SLH °C 0 to SLH °F
	R	SLL to 1769 °C	0 to SLH °C
	S	SLL to 3216 °F	0 to SLH °F
	B	SLL to 1820 °C SLL to 3308 °F	0 to SLH °C 0 to SLH °F
	E	SLL to 1000 °C SLL to 1832 °F	0 to SLH °C 0 to SLH °F
	N	SLL to 1300 °C SLL to 2372 °F	0 to SLH °C 0 to SLH °F
	T	SLL to 400.0 °C SLL to 752.0 °F	-199.9 to SLH °C -199.9 to SLH °F
	W5Re/W26Re	SLL to 2320 °C SLL to 4208 °F	0 to SLH °C 0 to SLH °F
	PLII	SLL to 1390 °C SLL to 2534 °F	0 to SLH °C 0 to SLH °F

Factory set value varies depending on the instrument specification.

Input type	Setting range		
	Setting limiter high	Setting limiter low	
TC	U	SLL to 600.0 °C SLL to 999.9 °F	-199.9 to SLH °C -199.9 to SLH °F
	L	SLL to 800 °C SLL to 1600 °F	0 to SLH °C 0 to SLH °F
RTD	Pt100	SLL to 649.0 °C SLL to 999.9 °F	-199.9 to SLH °C -199.9 to SLH °F
	JPt100		
Voltage	0 to 5 V DC	SLL to 9999 (Programmable range)	-1999 to SLH (Programmable range)
	0 to 10 V DC *		
	1 to 5 V DC		
Current	0 to 20 mA DC		
	4 to 20 mA DC		

* Z-1010 specification

Change Settings

Example: When the display range is scaled to 0.0 to 400.0 for a voltage input of 1 to 5 V DC.

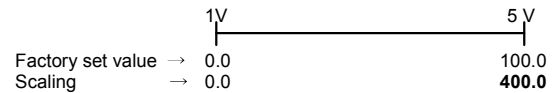

1. Set Cod to 0001, and press the SET key. The display will go to SLH.

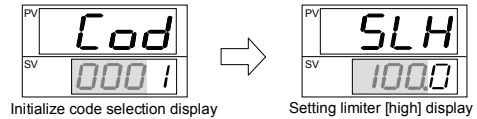

2. The high-lighted digit indicates which digit can be set. Press <R/S key to high-light the first digit from the left.



3. Press the UP key to change the number to 4.

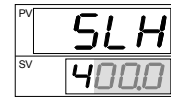

4. Press the SET key to store the new set value. The display goes to SLL.
5. Set SLL to 0.0.
6. Press the SET key to store the new set value. The display goes to the next parameter.

7.9 Decimal Point Position (PGdP)

Use to select a Decimal point position of the input range (voltage input and current input). PGdP is displayed only for voltage or current input.

Inappropriate settings may result in malfunction.

Set value	Description
0000	No decimal place (□□□□)
0001	One decimal place (□□□.□) [Factory set value]
0002	Two decimal places (□□.□□)
0003	Three decimal places (□.□□□)

Change Settings

Example: Change the Decimal point position from "One decimal place (0001)" to "No decimal place (0000)"

1. Press the SET key two times at SLH until PGdP is displayed.
2. Press the DOWN key to change the number to 0.

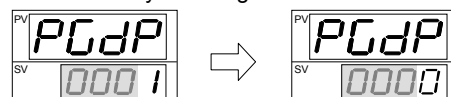

3. Press the SET key to store the new set value. The display goes to the next parameter.

8. ERROR DISPLAYS

■ Error display

Err	RAM failure (Incorrect set data write, etc.)	Turn off the power at once. If an error occurs after the power is turned on again, please contact RKC sales office or the agent.
------------	--	--

■ Over-scale and Underscale

Measured value (PV) [Flashing]	PV is outside of input range.	 WARNING To prevent electric shock, always turn off the power before replacing the sensor. Check Input type, Input range and connecting state of sensor. Confirm that the sensor or wire is not broken.
0000 [Flashing]	Over-scale: PV is above the high input display range limit.	
UUUU [Flashing]	Underscale: PV is below the low input display range limit.	

9. INPUT RANGE TABLE

Input type	Model code	Input type	Model code	Input type	Model code	Input type	Model code	Input type	Model code					
K	0 to 200 °C	K1 01	J	0 to 800 °F	J1 A1	N	0 to 1200 °C	N1 01	U	*2 -199.9 to +100.0 °C	U1 02	Pt100	-100.0 to +100.0 °F	D1 A4
	0 to 400 °C	K1 02		0 to 1600 °F	J1 A2		0 to 1300 °C	N1 02		0.0 to 400.0 °C	U1 03		-100.0 to +300.0 °F	D1 A5
	0 to 600 °C	K1 03		0 to 2192 °F	J1 A3		0 to 2300 °F	N1 A1		-199.9 to +999.9 °F	U1 A1		0.0 to 100.0 °F	D1 A6
	0 to 800 °C	K1 04		0 to 400 °F	J1 A6		0 to 2372 °F	N1 A2		-100.0 to +200.0 °F	U1 A2		0.0 to 200.0 °F	D1 A7
	0 to 1000 °C	K1 05		0 to 300 °F	J1 A7		*2 -199.9 to +400.0 °C	T1 01		0.0 to 999.9 °F	U1 A3		0.0 to 400.0 °F	D1 A8
	0 to 1200 °C	K1 06		0 to 1600 °C	R1 01	*2 -199.9 to +100.0 °C	T1 02	0 to 400 °C		L1 01	0.0 to 500.0 °F		D1 A9	
	0 to 1372 °C	K1 07	*1 0 to 1769 °C	R1 02	-100.0 to +200.0 °C	T1 03	0 to 800 °C	L1 02		-199.9 to +649.0 °C	P1 01			
	0 to 100 °C	K1 13	*1 0 to 1350 °C	R1 04	0.0 to 350.0 °C	T1 04	0 to 800 °F	L1 A1		-199.9 to +200.0 °C	P1 02			
	0 to 300 °C	K1 14	*1 0 to 3200 °F	R1 A1	*2 -199.9 to +752.0 °F	T1 A1	0 to 1600 °F	L1 A2		-100.0 to +50.0 °C	P1 03			
	0 to 450 °C	K1 17	*1 0 to 3216 °F	R1 A2	-100.0 to +200.0 °F	T1 A2	-199.9 to +649.0 °C	D1 01		-100.0 to +100.0 °C	P1 04			
	0 to 500 °C	K1 20	*1 0 to 1600 °C	S1 01	-100.0 to +400.0 °F	T1 A3	-199.9 to +200.0 °C	D1 02		-100.0 to +200.0 °C	P1 05			
	0 to 800 °F	K1 A1	*1 0 to 1769 °C	S1 02	0.0 to 450.0 °F	T1 A4	-100.0 to +50.0 °C	D1 03		0.0 to 50.0 °C	P1 06			
	0 to 1600 °F	K1 A2	*1 0 to 3200 °F	S1 A1	0.0 to 752.0 °F	T1 A5	-100.0 to +100.0 °C	D1 04		0.0 to 100.0 °C	P1 07			
	0 to 2502 °F	K1 A3	*1 0 to 3216 °F	S1 A2	W5Re/ W26Re	0 to 2000 °C	W1 01	-100.0 to +200.0 °C		D1 05	0.0 to 200.0 °C		P1 08	
20 to 70 °F	K1 A9	400 to 1800 °C	B1 01	0 to 2320 °C	W1 02	0.0 to 50.0 °C	D1 08	0.0 to 300.0 °C	P1 09					
J	0 to 200 °C	J1 01	*1 0 to 1820 °C	B1 02	0 to 4000 °F	W1 A1	0.0 to 100.0 °C	D1 07	0 to 5 V DC	4 01				
	0 to 400 °C	J1 02	*1 800 to 3200 °F	B1 A1	0 to 1300 °C	A1 01	0.0 to 200.0 °C	D1 08	0 to 10 V DC **	5 01				
	0 to 600 °C	J1 03	*1 0 to 3308 °F	B1 A2	0 to 1390 °C	A1 02	0.0 to 300.0 °C	D1 09	1 to 5 V DC	6 01				
	0 to 800 °C	J1 04	0 to 800 °C	E1 01	0 to 1200 °C	A1 03	0.0 to 500.0 °C	D1 10	0 to 20 mA DC	7 01				
	0 to 1000 °C	J1 05	0 to 1000 °C	E1 02	0 to 2400 °F	A1 A1	-199.9 to +999.9 °F	D1 A1	4 to 20 mA DC	8 01				
	0 to 1200 °C	J1 06	0 to 1600 °F	E1 A1	0 to 2534 °F	A1 A2	-199.9 to +400.0 °F	D1 A2						
0 to 450 °C	J1 10	0 to 1832 °F	E1 A2	U *2 -199.9 to +600.0 °F	U1 01	-199.9 to +200.0 °F	D1 A3							

*1 0 to 399 °C / 0 to 799 °F. Accuracy is not guaranteed.

*2 -199.9 to -100.0 °C / -199.9 to -158.0 °F. Accuracy is not guaranteed.

*3 This input type can not be selected in the Z-1021 specification.

**Z-1010 specification

10. REMOVING THE INTERNAL ASSEMBLY

Usually, this instrument is not necessary to remove the internal assembly from the case. When removing the internal assembly without disconnecting the external wiring, take the following steps.

WARNING

- To prevent electric shock or instrument failure, only qualified personnel should be allowed to pull out the internal assembly.
- To prevent electric shock or instrument failure, always turn off the power before pulling out the internal assembly.
- To prevent injury or instrument failure, do not touch the internal printed wiring board.

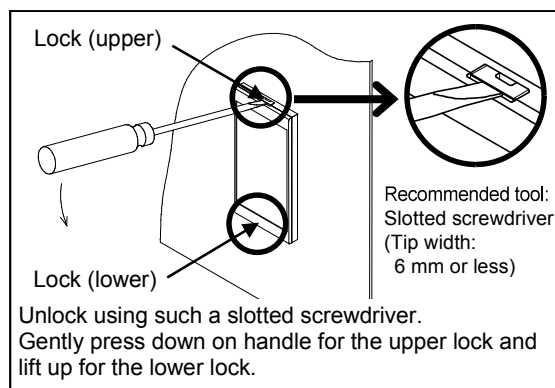

Apply pressure very carefully when removing internal assembly to avoid damage to the frame.



To conform to IEC61010-1 requirements for protection from electric shock, the internal assembly of this instrument can only be removed with an appropriate tool.



Unlocking points (marked with "O") depend on the model as follows:

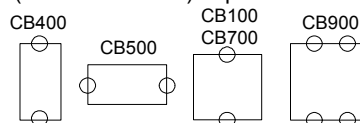

The first edition: JAN. 2012 [IMQ00]

APPENDIX G BELIMO CONTROL VALVE MANUAL

LR24-MFT US, LR24(-S), LR230(-S) rotary actuators for ball valves



Rotary actuator for 2 and 3-way ball valves DN 15...32

**Modulating actuator
(AC/DC 24 V)
LR24-MFT US**

**Open-close actuator
(AC/DC 24V & AC 230V)
LR24(-S), LR230(-S)**

Application

Operation of characterized control valves and open-close valves.

Mode of operation

LR24-MFT US: modulating control is effected by means of a standard 0...10 VDC control signal.

LR24(-S) & LR230(-S): Open-close control for open-close valves.

LR24-MFT US is suitable for the following characterized control valves

2-way	R209	R210	R211	R212	R213	R214	R217	R218	R219	R222	R223	R224	R229
3-way	R309	R310	R311	R312	R313	-	R317	R318	-	R322	R323	-	R329
DN [mm]	15			20			25			32			

LR24(-S), LR230(-S) are suitable for the following open-close valves

2-way	R215	R220	R225	R230
3-way	R315	R320	R325	R330
DN [mm]	15	20	25	32

Basic technical data

Connection	Cable 1 m, 4 × 0.75 mm ²
Manual operation	Pushbutton, self-resetting
Ambient temperature range	-5 ... +50 °C
Temperature of medium	-5 ... +100 °C
Non-operating temperature	-40 ... +80 °C
Humidity test	EN 60730-1
Torque	min. 4 Nm (at nominal voltage)
Sound power level	max. 35 dB (A)
Position indication	Scale plate 0...1
EMC	CE according to 89/336/EEC, 92/31/EEC, 93/68/EEC
Maintenance	Maintenance-free

LR24-MFT US technical data

For wire sizing	3 VA (I _{max} 8.3 A @ 5 ms)
Power supply range	AC 19.2...28.8 V; DC 21.6...28.8 V
Power consumption	Running: 2 W; Holding: 1 W
Control signal Y	DC 0...10 V @ 100 k input impedance
Operating range	DC 2...10 V for 0...100%
Feedback signal U	DC 2...10 V (I _{max} 0.5 mA) for 0...100%
Protection class	⚡ (Safety extra-low voltage)
Degree of protection	IP 54
Running time	150 s
Uni-rotation	±5 %
Weight	0.65 kg

LR24(-S) technical data

For wire sizing	2 VA (I _{max} 8.3 A @ 5 ms)
Power supply range	AC 19.2...28.8 V DC 21.6...28.8 V
Power consumption	1.5 W

LR230(-S) technical data

For wire sizing	12 VA (I _{max} 8.3 A @ 5 ms)
Power supply range	AC 198...264 V
Power consumption	1 W

Angle of rotation	90°	90°
Protection class	⚡ (Safety extra-low voltage)	II (Totally insulated)
Degree of protection	IP 40	IP 40
Running time	80...110 s (0...4Nm)	80...110 s (0...4Nm)
Weight	0.55 kg	0.55 kg

Product Features

Simple direct mounting on the characterized control valve using only one screw. The mounting position in relation to the characterized control valve can be selected in 90° steps.

Functional reliability: The actuator is overload-proof and automatically stops when the end stops are reached.

Manual operation possible by lever (the gearing latch remains disengaged as long as the self-resetting lever is pressed). Do not use manual operation before disconnecting the power supply.

Ordering examples:

- LR24** rotary actuator with **R...** ball valve fitted
- Order code: **R...+LR24**
- LR24** rotary actuator and **R...** ball valve supplied separately
- Order code: **R.../LR24**
- LR24** rotary actuator packed loose
- Order code: **LR24**

Important notes on page 2

For detailed information of multifunction, please refer to 8_MFT-AP_0102_E.pdf

Wiring diagram

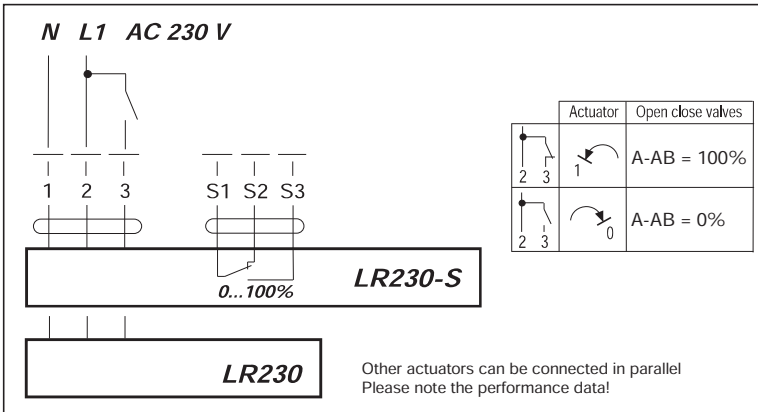
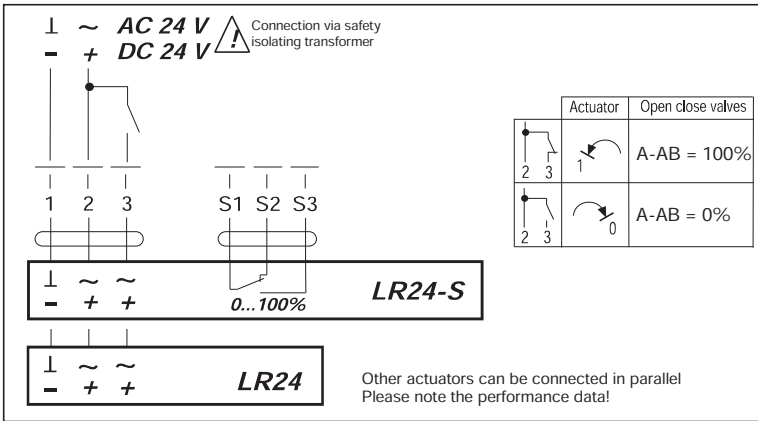
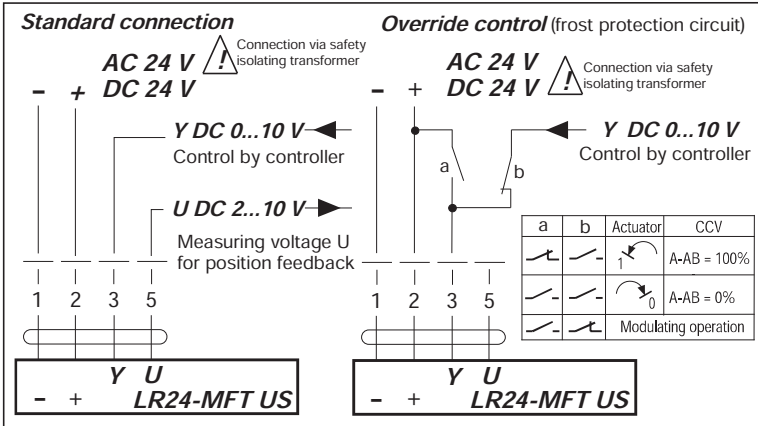

Installation of LR.. rotary actuator with R... ball valve

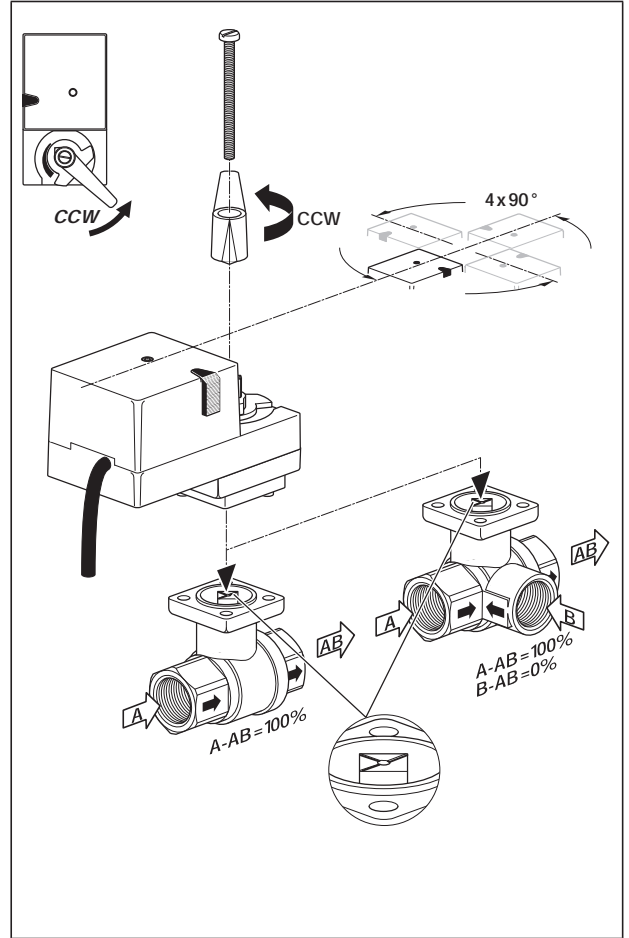

Installation dimension, LR.. + R..

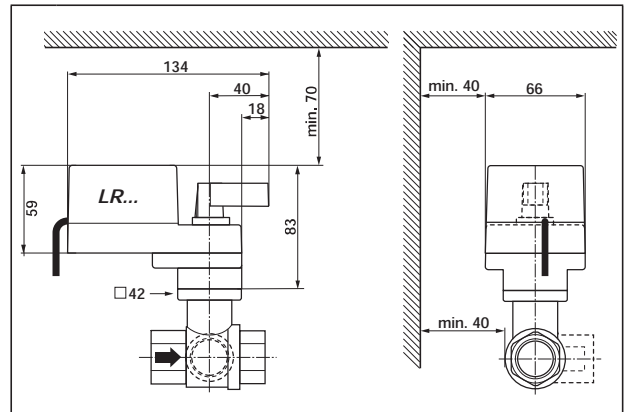

Ordinary ball valves are unsuitable as control devices

In order to ensure good stability of control, a hydraulic final controlling element must possess a flow characteristic that supplements the non-linear characteristic of the heat exchanger in the HVAC system.

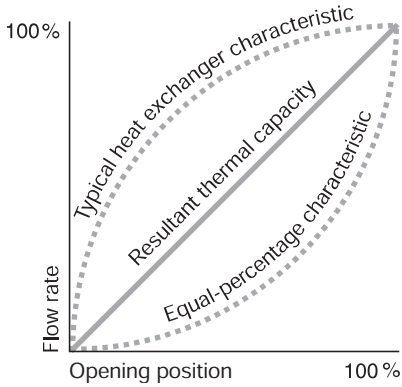

Characteristics of an ideal hydraulic final controlling element

An equal-percentage valve characteristic is desirable in order to produce a linear relationship between the thermal output and the opening position of the final controlling element. This means that the flow rate increases very slowly as the final controlling element begins to open.

Unfortunately, this characteristic is severely distorted in ordinary ball valves.

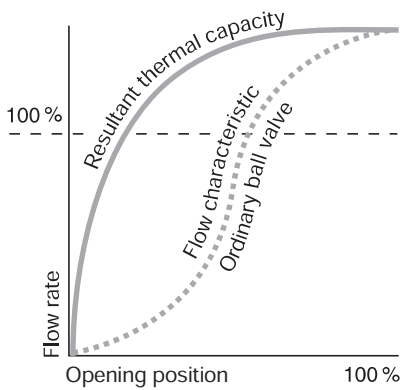

Characteristic of an ordinary ball valve

The reason for this is that an ordinary ball valve has an extremely high flow coefficient (k_{VS} value) compared with its nominal size, several times that of a comparable globe valve.

Therefore, an ordinary ball valve is not very suitable for performing control functions:

- Flow coefficient excessive due to the design
- Flow control inadequate in the part-load range

Belimo adds "characterized control" to ball valves

Belimo has succeeded in solving the problem of the distorted flow characteristic of ordinary ball valves.

A so-called "characterizing disc" in the inlet of the characterized control valve converts the valve's characteristic to the equal-percentage kind.

The side of the characterizing disc facing the ball is concave and in contact with the surface of the ball. Thus, the actual flow is regulated by the hole in the ball and by the V-shaped aperture in the characterizing disc.

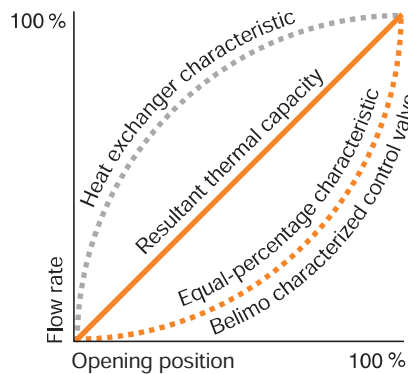

Characteristic of a Belimo characterized control valve

The k_{VS} value is reduced and corresponds approximately to that of a globe valve of comparable size. In order to avoid having to fit pipe reducers in the majority of cases, each valve size is also available with an appropriate choice of k_{VS} values.

Advantages of the Belimo characterized control valve

- Equal-percentage characteristic
- No initial jump in flow on opening
- Excellent stability of control thanks to the characterizing disc

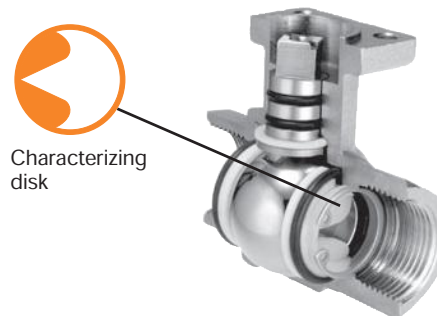

- k_{VS} values similar to those of globe valves of comparable size
- Fewer pipe reducers needed
- Better part-load characteristics and less prone to vibration, greater stability of control
- Tight-sealing (2-way)

Elements of the characterized control valve

- 1 Simple direct mounting using a central screw. The rotary actuator can be mounted in four different positions
- 2 Square stem head for form-fit attachment of the rotary actuator
- 3 Identical mounting flange for all sizes
- 4 Stem with two O-ring seals for a long service life
- 5 Ball and stem made of stainless steel

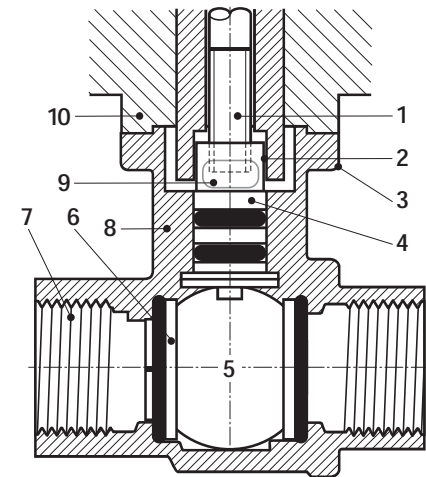

- 6 Characterizing disc produces equal-percentage flow characteristic
- 7 Internal thread connection (ISO 7/1)
- 8 Forged fitting, nickel-plated brass body
- 9 Vent window to prevent the accumulation of condensation
- 10 Thermal decoupling of the actuator from the ball valve

Optimum choice of k_{VS} valves of identical size

- Better controllability
- Lower installation costs

The Belimo range of characterized control valves includes 2-way and 3-way types. These are available in a variety of sizes and with a choice of k_{VS} values.

A characterized control valve is supplied as a unit complete with a suitable Belimo rotary actuator.

Sizing diagram Characterized control valves

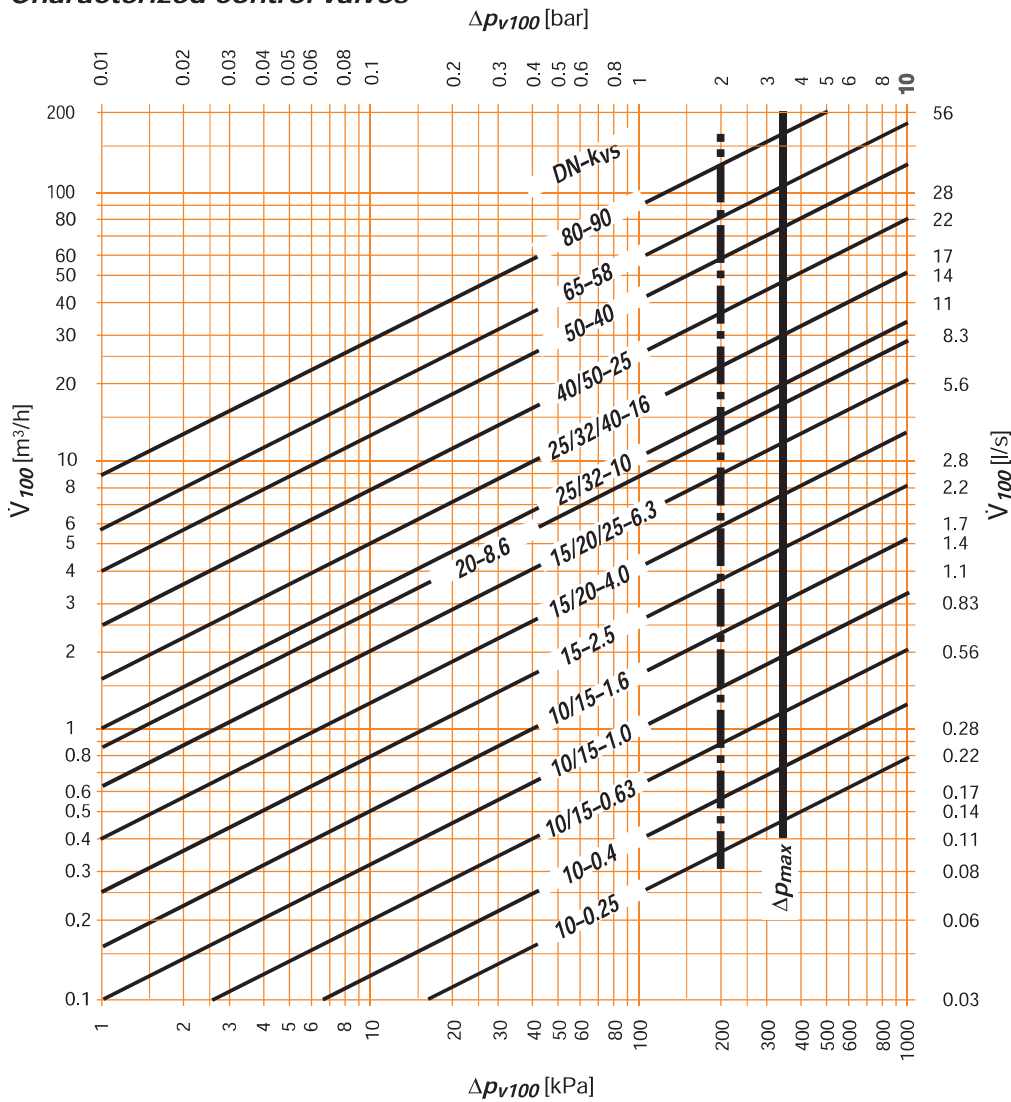

Legend

- Δp_{max}
Maximum permitted pressure difference for a long service life across control path A-AB referred to the whole range of opening
- Δp_{max}
For low-noise operation
- Δp_{v100}
Pressure difference with ball valve fully open
- \dot{V}_{100}
Nominal flow rate with Δp_{v100}

Formula k_{vs}

$$k_{vs} = \sqrt{\frac{\dot{V}_{100}}{\frac{\Delta p_{v100}}{100}}}$$

- k_{vs} [m³/h]
- \dot{V}_{100} [m³/h]
- Δp_{v100} [kPa]

Definition of Δp_s

Closing pressure at which the actuator can still seal the valve tightly allowing for the appropriate leakage rate

Sizing table Open-close ball valves

Differential pressure Δp_{v100} [kPa]	Connection				k_{vs} [m ³ /h]	DN [mm]	2-way 	3-way
	0.1	1	3	10				
Flow rate \dot{V}_{100} [m ³ /h]	0.27	0.86	1.49	2.72	8.6	15	R215 R415 R615R	R315 R515 R715R
	0.66	2.1	3.6	6.6	21	20	R220 R420 R620R	R320 R520 R720R
	0.82	2.6	4.5	8.2	26	25	R225 R425 R625R	R325 R525 R725R
	0.51	1.6	2.77	5.06	16	32	R230 R430	R330 R530
	1.01	3.2	5.54	10.12	32	32	R232 R432 R632R	R332 R532 R732R
	1.01	3.2	5.54	10.12	32	40	R240 R440 R640R	R340 R540 R740R
	1.55	4.9	8.49	15.5	49	50	R250 R450 R650R	R350 R550 R750R
	5.05	16	27.73	50.63	160	65	R665R	-
	5.05	16	27.73	50.63	160	80	R680R	-

Selection

k _{vs} [m³/h]	DN		Type			Suitable rotary actuators					
	mm	Inches	Internal thread	External thread	Flange	Modulating DC 0...10 V	3-point	Emerg. control function			
0.25	10	3/8"	R205K	R405K	–	TRD24-SR AC/DC 24 V	TRD24-3 AC 24 V				
0.4	10	3/8"	R206K	R406K	–						
0.63	10	3/8"	R207K	R407K	–						
1	10	3/8"	R208K	R408K	–						
1.6	10	3/8"	R209K	R409K	–						
0.63	15	1/2"	R209	R409	R609R	TR24-SR AC/DC 24 V	TR24-3 AC 24 V				
1	15	1/2"	R210	R410	R610R						
1.6	15	1/2"	R211	R411	R611R						
2.5	15	1/2"	R212	R412	R612R						
4	15	1/2"	R213	R413	R613R						
6.3	15	1/2"	R214	R414	R614R						
4	20	3/4"	R217	R417	R617R						
6.3	20	3/4"	R218	R418	R618R						
8.6	20	3/4"	R219	R419	R619R						
6.3	25	1"	R222	R422	R622R						
10	25	1"	R223	R423	R623R						
16	25	1"	R224	R424	R624R						
10	32	1 1/4"	R229	R429	–	LR24-SR AC/DC 24 V	NR(Y)24-SR AC/DC 24 V				
16	32	1 1/4"	R231	R431	R631R						
16	40	1 1/2"	R238	R438	R638R						
25	40	1 1/2"	R239	R439	R639R						
25	50	2"	R248	R448	R648R						
40	50	2"	R249	R449	R649R						
58	65	2 1/2"	–	–	R664R						
90	80	3"	–	–	R679R						
									NR24-3 AC 24 V	NR230-3 AC 230 V	LF24-SR AC/DC 24 V
						AFR24-SR AC/DC 24 V					

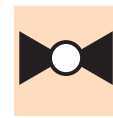

2-way characterized control valves
DN 10...80



For modulating control of cold and hot water

Equal-percentage characteristic

Applications

- Water-side control of air handling apparatus in ventilation and air-conditioning systems
- Water-side control in heating systems

Mode of operation

The characterized control valve is operated by a rotary actuator. The actuators are controlled by a standard modulating or 3-point control system and move the ball of the valve – the throttling device – to the opening position dictated by the control signal.

Product features

Equal-percentage characteristic of the flow rate ensured by the integral characterizing disc.

Manual operation by lever after disengaging the gearing latch on the Type TR.., LR.. or NR.. rotary actuator (manual operation not possible with LF./AFR..).

Ordering

An order for an R2.. characterized control valve includes a suitable rotary actuator.

Ordering examples: (with NR24-SR)

- R231 characterized control valve with NR24-SR
 - Rotary actuator fitted
 - Order code: R231+NR24-SR
- R231 characterized control valve and NR24-SR
 - Rotary actuator supplied separately
 - Order code: R231/NR24-SR

Technical data

Flow media	Cold and hot water, Water with max. 50% volume of glycol
Temperature of medium	+5 °C...+110 °C (lower or higher temperatures on request)
Rated pressure p _s	See table below
Flow characteristic	Control path A–AB: equal percentage (to VDI/VDE 2173) DN 10...15* n(gl) = 3.2, optimized in opening range DN 20...50** n(gl) = 3.9, optimized in opening range
Rangeability	DN 10...15* Sv > 50 DN 20...50** Sv > 100
Leakage rate	Air bubble-tight (BO 1, DIN 3230 Part 3)
Pipe connector	R2.. internal thread to ISO 7/1 R4.. external thread to ISO 228/1 R6.. flange PN 6 to EN 1092/1
Differential pressure Δp _{max}	350 kPa (200 kPa for low-noise operation)
Closing pressure Δp _s	1400 kPa
Angle of rotation	90°(operating range 15°...90°)
Installation position	Upright to horizontal (in relation to the stem)
Maintenance	Maintenance-free

Materials

Fitting	Forged, nickel-plated brass body
Valve cone	Stainless steel / R6.. chrome-plated brass
Seal	PTFE
Stem	Stainless steel / R6.. chrome-plated brass
Stem seal	EPDM
Flange ring	DN 15/20 Zinc-plated steel DN 25...80 Aluminum
Flange joint surface	Nickel-plated brass
Characterizing disk	TEFZEL

* Up to k_{vs} 2.5 ** And DN15 k_{vs} > 4

Type	Rated pressure p _s [kPa]
R205.. – R229	4140
R405.. – R429	4140
R231 – R249	2760
R431 – R449	2760
R609R – R679R	600

Important

- Sizing diagram for characterized control valves: page 7
- Dimensions: pages 12, 33, 34 and 36
- Installation instructions: pages 33, 34, 36
- Please note the information provided on pages 2 and 38 to 40 regarding use, installation, project design, commissioning and maintenance
- Pipe connectors can be supplied as an accessory: page 13

2-way ball valves with internal thread

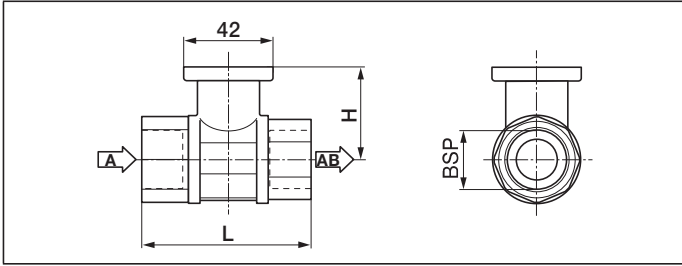

DN	Dimensions		Thread		Weight
	L	H	BSP	Max. screwing depth	
[mm]	[mm]	[mm]	[Inches]	[mm]	[kg]
10	52	35	3/8"	10	0.3
15	67	45	1/2"	13	0.4
20	78	47.5	3/4"	13	0.55
25	87	47.5	1"	17	0.7
32	105	47.5	1 1/4"	19	0.9
32	105	52	1 1/4"	19	1.05
40	111	52	1 1/2"	19	1.15
50	125	58	2"	22	1.8

2-way ball valves with external thread

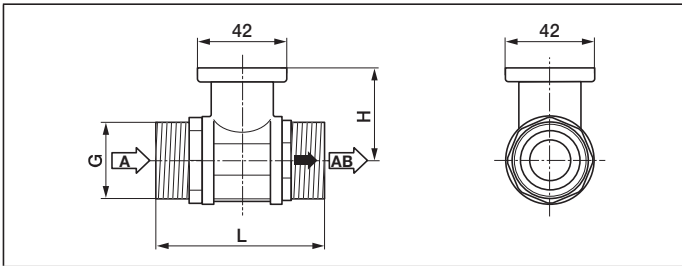

DN	Dimensions		Thread	Weight
	L	H	G	
[mm]	[mm]	[mm]	[Inches]	[kg]
10	69	31.5	3/4"	0.4
15	74	44	1"	0.6
20	85.5	46	1 1/4"	0.8
25	84.5	46	1 1/2"	0.9
32	97.5	46	2"	1.1
32	102	50.5	2"	1.3
40	103	50.5	2 1/4"	1.4
50	115.5	56	2 3/4"	2.3

2-way ball valves with flanges

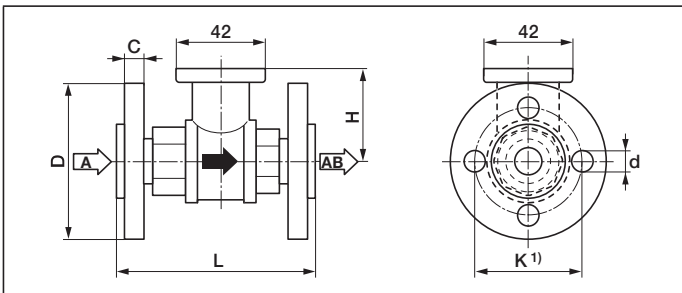

DN	Dimensions		Flange				Weight
	L	H	D	C	K	d	
[mm]	[mm]	[mm]	[mm]	[mm]	[mm]	[mm]	[kg]
15	101.5	45	80	15	55	4 x 11	1.3
20	112	47.5	90	15	65	4 x 11	1.7
25	132	47.5	100	20	75	4 x 11.5	1.7
32	143.5	52	120	17	90	4 x 14	2.3
40	149.5	52	130	18	100	4 x 14	2.7
50	165	58	140	18	110	4 x 14	3.7
65	180.5	69	160	18	130	4 x 14	6.0
80	191.5	69	190	20.5	150	4 x 18	7.6

APPENDIX H WATER PRESSURE REDUCING VALVE

Pressure reducing valves

series 5360 - 5362 - 5365 - 5366



cert. n° 0003
ISO 9001

01026/05 GB

Replaces 01026/01 GB



Function

Pressure reducers are devices which, when installed on a water system, reduce and stabilise the pressure entering from the mains. This incoming pressure is generally too high and variable to be applied directly to domestic systems.

A basic characteristic of a good pressure reducer is that it makes it possible to maintain constant downstream pressure when the upstream pressure varies.



Product range

Series 5360.1	Pressure reducing valve, male connections, with pressure gauge	Sizes 1/2", 3/4", 1", 1 1/4", 1 1/2" M
Series 5360.0	Pressure reducing valve, male connections, with pressure gauge connection	Sizes 1/2", 3/4", 1", 1 1/4", 1 1/2" M
Series 5362.1	Pressure reducing valve, female connections, with pressure gauge	Sizes 1/2", 3/4", 1" F
Series 5362.0	Pressure reducing valve, female connections, with pressure gauge connection	Sizes 1/2", 3/4", 1" F
Series 5365.1	Pressure reducing valve, male connections, with double pressure gauge	Sizes 1 1/2", 2" M
Series 5365.0	Pressure reducing valve, male connections, with double pressure gauge connection	Sizes 1 1/2", 2" M
Code 536660	Pressure reducing valve, flanged connections, with double pressure gauge	Size DN 65

Technical specification

series ↗	5360/5362	5365	5366
Materials:			
- Body:	brass EN 1982 CB753S	bronze DIN 50930-6 RG5 PB3	bronze DIN 50930-6 RG5 PB3
- Cover:	brass EN 12165 CW617N	brass EN 1982 CB753S	brass EN 1982 CB753S
- Membrane:	NBR	NBR	NBR
- Seal:	NBR	NBR	NBR
- Seat and filter:	stainless steel	stainless steel	stainless steel
Performance:			
- Max pressure upstream:	25 bar	25 bar	16 bar
- Downstream pressure setting range:	0,5–6 bar	0,5–6 bar	0,5–6 bar
- Factory setting:	3 bar	3 bar	3 bar
- Max working temperature:	80°C	80°C	80°C
- Pressure gauge scale:	0–10 bar	0–25 bar upstream 0–10 bar downstream	0–25 bar upstream 0–10 bar downstream
- Medium:	water	water	water
- Certification:	EN1567	EN1567	-
- Acoustic group:	I	-	-
Connections:	- 5360; 1/2"–1 1/2" M with union connection - 5362 1/2"–1" F	1 1/2"–2" M with union connection	DN 65 flanged, coupled with flat counterflanges EN 1092-1, PN 16
Pressure gauge connections:	one of 1/4" F	two of 1/4" F	two of 3/8" F

Dimensions

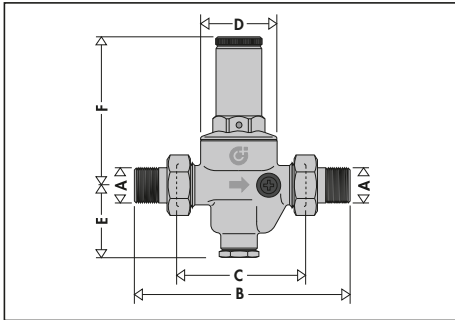

Code	A	B	C	D	E	F
536040/1	1/2"	140	76	∅ 51	53,5	89,5
536050/1	3/4"	160	90	∅ 60	54	111,5
536060/1	1"	180	95	∅ 60	54	111,5
536070/1	1 1/4"	200	110	∅ 72	63	126
536080/1	1 1/2"	220	120	∅ 72	63	126

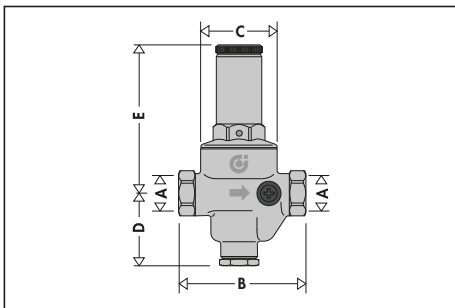

Code	A	B	C	D	E
536240/1	1/2"	81	∅ 51	53,5	89,5
536250/1	3/4"	95	∅ 60	54	111,5
536260/1	1"	100	∅ 60	54	111,5

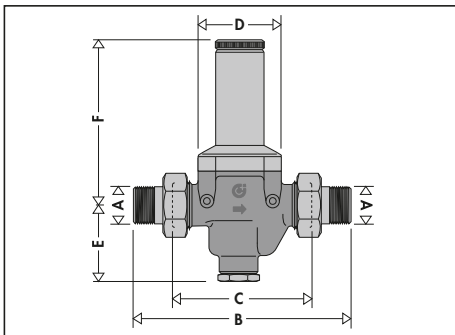

Code	A	B	C	D	E	F
536580/1	1 1/2"	260	160	110	97	201
536590/1	2"	280	160	110	94	204

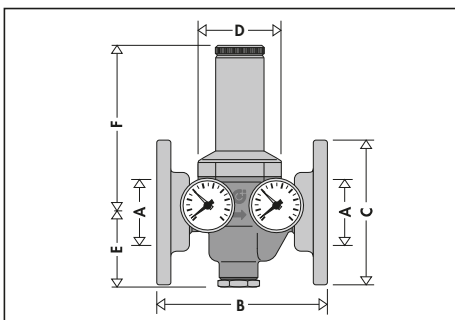

Code	A	B	C	D	E	F
536660	DN 65	225	∅ 185	110	94	204

Operating principle

The operation of the pressure reducing valve is based on the balancing of two opposing forces:

- 1 the thrust of the **spring** towards the **opening** of the obturator.
- 2 the thrust of the **membrane** towards the **closing** of the obturator.

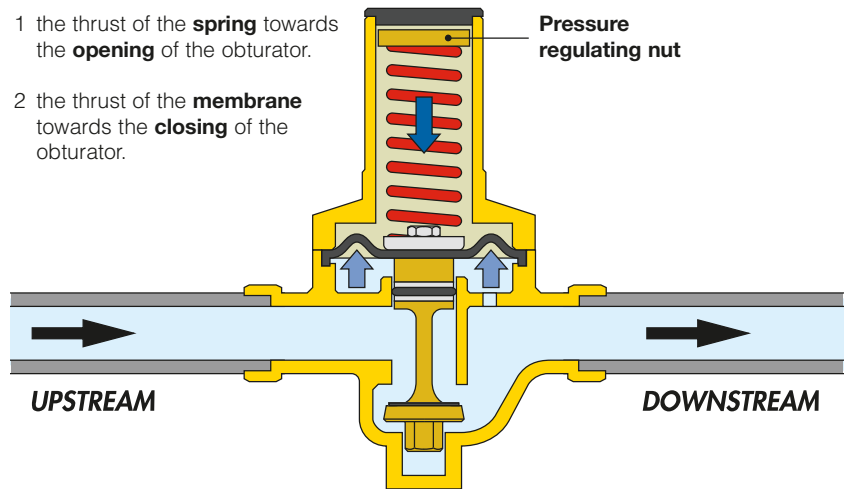

Operating with flow

When a draw-off point is opened on the water main, the force of the spring prevails over the opposing pressure of the membrane; the obturator moves downwards, allowing water to pass.

The greater the demand for water, the lower the pressure under the membrane, thus permitting more fluid to flow through the obturator.

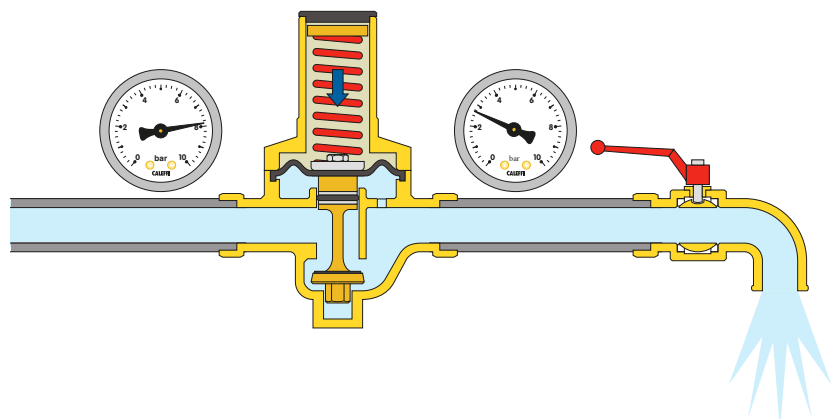

Operating without flow

When the draw-off point is fully closed, the downstream pressure rises and pushes the membrane upwards.

The obturator therefore closes, preventing the fluid from passing through and holding the pressure constant at the calibrated value.

A minimum difference in favour of the force exercised by the membrane in relation to that of the spring causes the device to close.

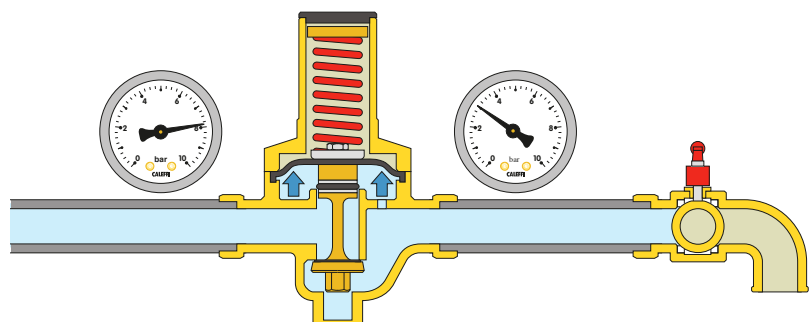

Construction details

Compensated seat

Caleffi pressure reducing valves are supplied with compensated seats. This means that the **set pressure value** downstream remains **constant** independently of the variations in value of the pressure upstream.

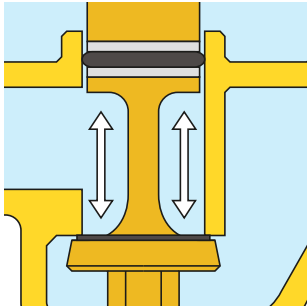

In the figure, the thrust towards opening is counterbalanced by the closing pressure acting on the compensating piston. As the latter has a surface equal to that of the obturator, the two forces cancel each other out.

Noiseless

The internal layout, designed to obtain the optimum fluid dynamic characteristics, has made it possible to achieve a noise level of less than 20 dB in all the tests carried out.

Thanks to this quality, Caleffi reducing valves are approved to the I acoustic group, in compliance with the EN 1567 European standard.

Low pressure losses

The internal fluid-dynamic shape of the reducing valve makes it possible to attain low pressure losses even when a large number of draw-off points are open.

This characteristic is important in relation to the high pressure losses caused by various devices present in modern systems, for example thermostatic mixers, which make it necessary to install reducers with minimum pressure losses.

High pressures

The zone exposed to the upstream pressure is constructed in such a way that it can operate at high pressure. Thanks to the PTFE anti-extrusion rings on the compensating piston, the valve can be used in continuous service with upstream pressures of up to 25 bar.

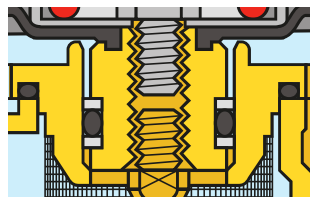

Seat seal

The fluid passage seat on which the obturator operates is made of stainless steel, which ensures the long-lasting operation of the device.

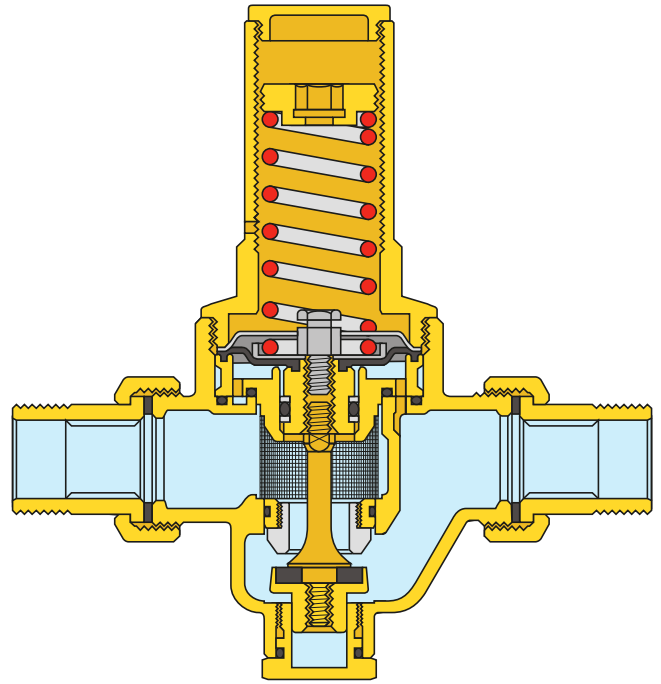
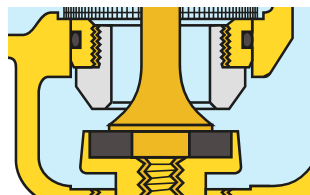

Sliding surfaces

The components most subject to wear due to the friction of moving parts are PTFE coated. This treatment considerably increases the life of the pressure reduction device.

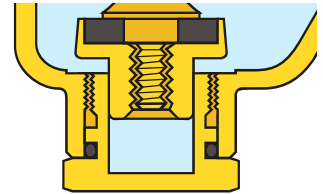

Removable cartridge

The cartridge containing the membrane, filter, seat, obturator and adjusting piston can be removed for maintenance and strainer cleaning purposes.

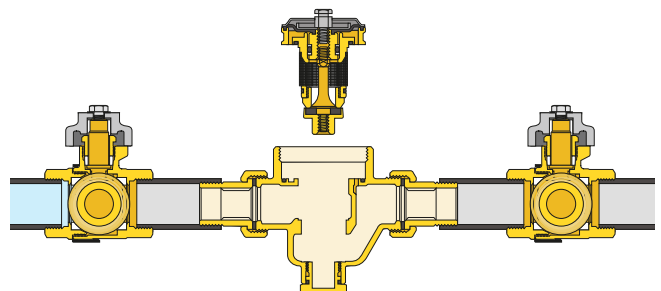

Certification

Pressure reducing valves are certified in accordance with the requirements of the EN 1567 European standard.

Hydraulic characteristics

Graph 1 (Circulation velocity)

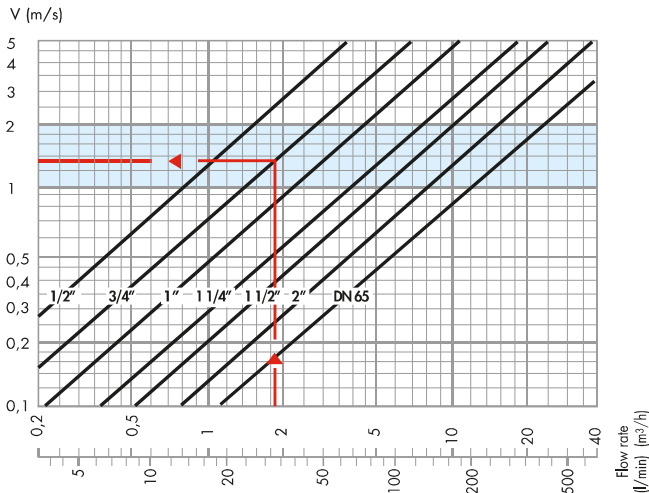

Graph 2 (Pressure drop)

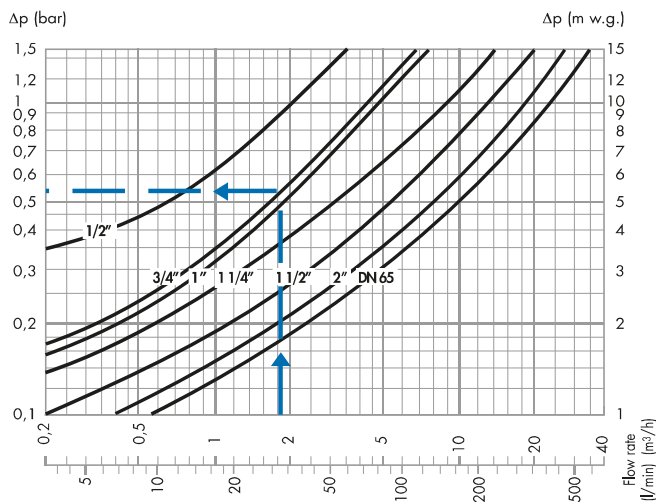

Reference conditions: Pressure upstream = 8 bar
Pressure downstream = 3 bar

Dimensioning

The typical flow rates of equipment commonly used in hot water systems are shown below to help in the selection of correct pipe sizes:

Table of typical flow rates

Bathtub, kitchen sink, dishwasher	12 litres/min
Shower	9 litres/min
Washbasin, bidet, washing machine, WC	6 litres/min

In order to prevent over-sizing of the pressure reducing valve and pipework, a simultaneous-use "correction factor" should be taken into account. In essence, the greater the number of users of the system, the lower the percentage of draw-off points opened at the same time.

Table showing simultaneous-use factors as %

Number of devices	Private dwelling %	Public building %	Number of devices	Private dwelling %	Public building %	Number of devices	Private dwelling %	Public building %
5	54	64,5	35	23,2	30	80	16,5	22
10	41	49,5	40	21,5	28	90	16	21,5
15	35	43,5	45	20,5	27	100	15,5	20,5
20	29	37	50	19,5	26	150	14	18,5
25	27,5	34,5	60	18	24	200	13	17,5
30	24,5	32	70	17	23	300	12,5	16,5

The steps to be taken for correct dimensioning are as follows:

- Calculate the total flow on the basis of the number and types of appliance present in the system, adding up their individual typical flow rates.

Example:

Single dwelling with 2 bathrooms
 2 bidets $G = 12$ l/min
 1 shower $G = 9$ l/min
 2 washbasins $G = 12$ l/min
 2 WCs $G = 12$ l/min
 1 bath $G = 12$ l/min
 1 kitchen sink $G = 12$ l/min
 1 dishwasher $G = 12$ l/min

$G_{tot} = 81$ l/min
No. of devices = 10

- The design flow is calculated using the simultaneous-use factors table.

Example:

$G_{des} = G_{tot} \cdot \% = 81 \cdot 41 \% = 33$ l/min

When sizing pressure reducing valves, it is advisable to keep the velocity of flow in the pipes at between 1 and 2 m/s. This prevents both noise in the pipework and rapid wear in the point of use equipment.

- The size of the pressure reducing valve is determined by means of graph 1, starting with the design flow figure and remembering that the ideal velocity is between 1 and 2 m/s (blue band).

Example:

for $G_{des} = 33$ l/min size 3/4" is selected (see graph 1)

- Using graph 2, still starting with the design flow figure, identify the pressure drop, intersecting the curve relating to the size already selected (the downstream pressure falls by a value equal to the pressure drop in relation to the zero flow set pressure).

Example:

for $G_{des} = 33$ l/min $\Delta p = 0,55$ bar (see graph 2)

Nominal flow rates

In accordance with the requirements of the EN 1567 European standard, these are the flow rates for each diameter, at an average speed of 2 m/s.

Size	1/2"	3/4"	1"	1 1/4"	1 1/2"	2"
Flow rate (m ³ /h)	1,27	2,27	3,6	5,8	9,1	14
Flow rate (l/min)	21,16	37,83	60	96,66	151,66	233,33

Installation

- 1 Prior to installation, open all the draw-off taps to empty the system and expel any air remaining in the pipework.
- 2 Install shut-off valves upstream and downstream to assist in future maintenance operations.
- 3 Install the pressure reducing valve in any position except upside down.

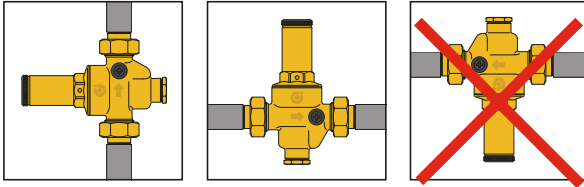

- 4 **Close the downstream shut-off valve.**
- 5 Calibrate by means of the spring pressure regulating nut located under the head cover, turning with a 10 mm hexagonal Allen key clockwise to increase the set value or anticlockwise to reduce it.
- 6 Check the required pressure on the pressure gauge. (Caleffi reducers come factory set at 3 bar).

Installation recommendations

1. Installation in pits

Installing pressure reducing valve inside pits is not recommended, for two reasons:

- it is very difficult, if not impossible, to read the pressure gauge.
- impurities may enter the device through the pressure relief outlet in the head cover.

2. Water hammer

This is one of the main causes of failure of pressure reducing valves. During the installation of "at risk" systems, the use of specific devices designed to absorb water hammer should be provided for.

Trouble-shooting

Some faults, which are usually due to the lack of suitable system safeguards, are sometimes incorrectly attributed to pressure reducing valves. The most frequent cases are:

1. Increased pressure downstream of the pressure reducing valve when a water heater is installed

This problem is due to the overheating of the water caused by the water heater.

The pressure cannot "leak", as the reducing valve is properly closed.

The solution is to install an expansion vessel (between the reducer and the water heater) to "absorb" the pressure increase.

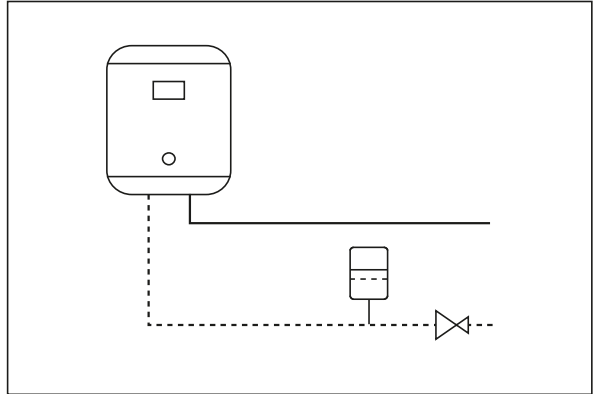

2. The pressure reducing valve does not maintain the set value

In the majority of cases, this problem arises from the presence of impurities on the seat seal causing leakage and consequent increases in the pressure downstream.

The solution consists of the preventive installation of a filter upstream of the pressure reducing valve and subsequently of maintenance and cleaning of the removable cartridge (see maintenance).

Maintenance

For cleaning, inspection or replacement of the entire cartridge:

- 1 Isolate the pressure reducing valve.
- 2 Unscrew the spring pressure regulating nut to release the spring tension.
- 3 Remove the head cover.
- 4 Extract the cartridge using two screwdrivers.
- 5 After inspection and cleaning if necessary, the complete cartridge can be refitted or replaced using a spare cartridge.
- 6 Recalibrate the pressure reducing valve.



System application diagram

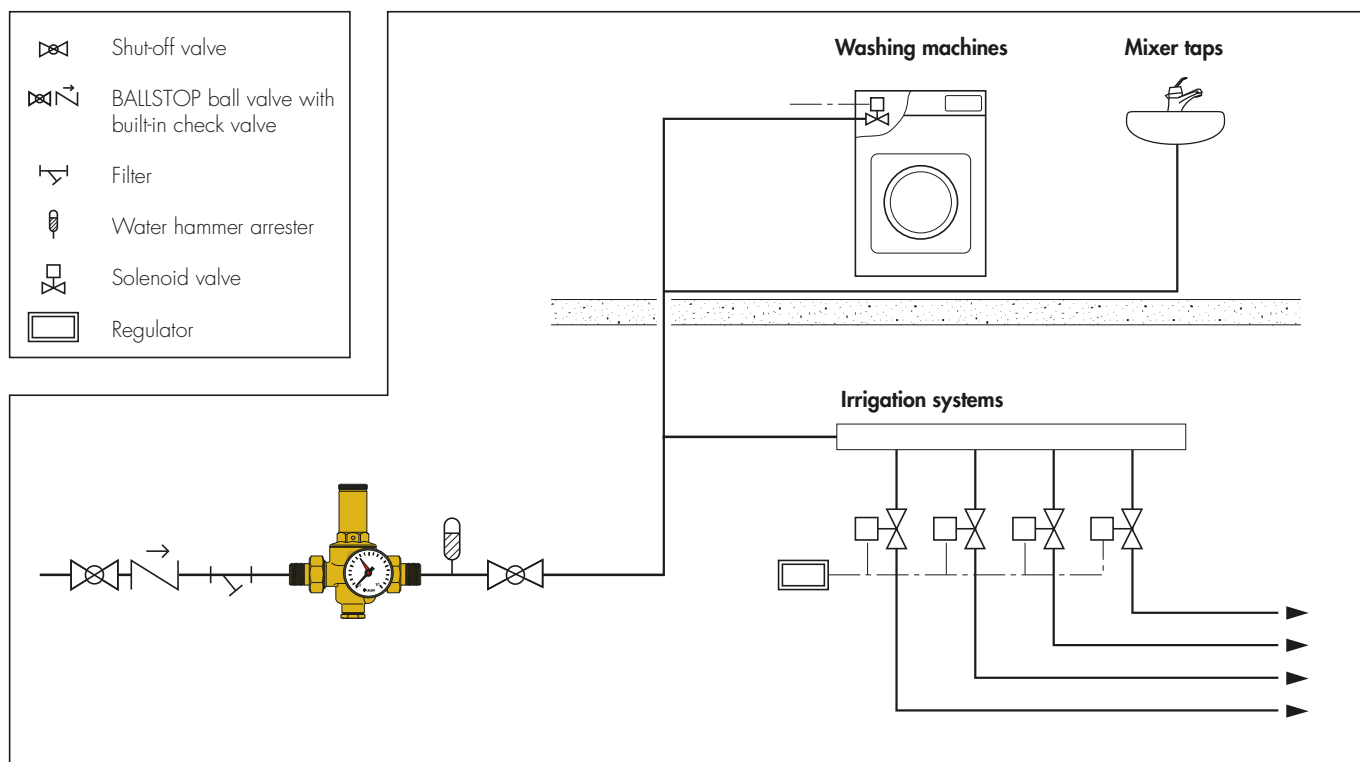

SPECIFICATION SUMMARIES

Series 5360

Pressure reducing valve with compensated seat to standard EN 1567. Threaded connections 1/2" M (from 1/2" to 1 1/2") with union. Brass body. Stainless steel seat and filter. NBR seal and membrane. Maximum working temperature 80°C. Maximum upstream pressure 25 bar. Downstream pressure setting range from 0,5 to 6 bar. Sliding surface heat-coated with PTFE. Cartridge with membrane, filter and obturator, removable for maintenance operations.

Series 5362

Pressure reducing valve with compensated seat. Threaded connections 1/2" F (from 1/2" to 1"). Brass body. Stainless steel seat and filter. NBR seal and membrane. Maximum working temperature 80°C. Maximum upstream pressure 25 bar. Downstream pressure setting range from 0,5 to 6 bar. Sliding surface heat-coated with PTFE. Cartridge with membrane, filter and obturator, removable for maintenance operations.

Series 5365

Pressure reducing valve with compensated seat to standard EN 1567. Threaded connections 1 1/2" M (from 1 1/2" to 2") with union. Bronze body. Stainless steel seat and filter. NBR seal and membrane. Maximum working temperature 80°C. Maximum upstream pressure 25 bar. Downstream pressure setting range from 0,5 to 6 bar. Sliding surface heat-coated with PTFE. Cartridge with membrane, filter and obturator, removable for maintenance operations.

Code 536660

Pressure reducing valve with compensated seat. Flanged connections PN 16 DN 65. Bronze body. Stainless steel seat and filter. NBR seal and membrane. Maximum working temperature 80°C. Maximum upstream pressure 16 bar. Downstream pressure setting range from 0,5 to 6 bar. Supplied with double pressure range: 0–25 bar upstream and 0–10 bar downstream. Sliding surface heat-coated with PTFE. Cartridge with membrane, filter and obturator, removable for maintenance operations.

We reserve the right to change our products and their relevant technical data, contained in this publication, at any time and without prior notice.



APPENDIX I CAT TRIPLEX PUMP - MANUAL - MODEL 1050



15 Frame Plunger Pumps

Standard Model

Stainless Steel Model

SS Flushed Model

Nickel Aluminum Bronze Model

1050
1051
1051C
1057

FEATURES

Superior Design

- Triplex plunger design provides smoother liquid flow.
- V-Packings are completely lubricated and cooled by the liquid being pumped.
- Special ported inlet manifold permits an external flush liquid providing cooling for hi-temp liquids and lubrication for low lubricity liquids.
- Lubricated Lo-Pressure Seals provide double protection against external leakage.
- Oil bath crankcase assures optimum lubrication.
- Close tolerance concentricity of the ceramic plunger offers perfect alignment and maximizes seal life.

Quality Materials

- Precision design 304 and 316 stainless steel valves and seats are hardened and polished for ultimate seating and extended valve life.
- Brass, Stainless Steel or Nickel Aluminum Bronze manifolds for strength and corrosion resistance.
- Special concentric, high-density, polished, solid ceramic plungers provide a true wear surface and extended seal life
- Specially formulated, CAT PUMP exclusive, V-Packings offers unmatched performance and seal life.
- Die cast aluminum crankcase provides high strength, minimum weight and precision tolerance control.
- Chrome-moly crankshaft gives unmatched strength and surface hardness.
- Oversized crankshaft bearings with greater loading capacity mean longer bearing life.

Easy Maintenance

- Wet-end is easily serviced without entering crankcase, requiring less time and effort.
- Valve assemblies are accessible without disturbing piping, for quick service.
- Inlet and discharge valve assemblies interchange for easier maintenance.
- Preset packings mean no packing gland adjustment is necessary, reducing maintenance costs.

⚠ WARNING

All systems require both a primary pressure regulating device (i.e., regulator, unloader) and a secondary pressure safety relief device (i.e., pop-off valve, safety valve). Failure to install such relief devices could result in personal injury or damage to the pump or to system components. CAT PUMPS does not assume any liability or responsibility for the operation of a customer's high pressure system.

SPECIFICATIONS

U.S. Measure

Metric Measure

STANDARD SPECIFICATIONS

Flow.....	10 GPM	(38 L/M)
Pressure Range.....	100 to 2200 PSI	(7 to 155 BAR)
RPM	958 RPM	(958 RPM)
Inlet Pressure Range	- 5 to 60 PSI	(-0.35 to 4 BAR)
Maximum Liquid Temperature	160°F	(71°C)

Above 130°F call CAT PUMPS for inlet conditions and elastomer recommendations.

ALTERNATE SPECIFICATIONS - MODEL 1050 ONLY

Flow*	12 GPM	(45 L/M)
Pressure Range*.....	100 to 1800 PSI	(7 to 125 BAR)
RPM*	1150 RPM	(1150 RPM)
Inlet Pressure Range*	20 to 60 PSI	(1.4 to 4 BAR)
Maximum Liquid Temperature*.....	100°F	(38°C)

*C.A.T. Required

COMMON SPECIFICATIONS

Bore.....	0.945"	(24 mm)
Stroke.....	1.180"	(30 mm)
Crankcase Capacity	42 oz.	(1.26 L)
Inlet Ports (2)	3/4" NPTF	(3/4" NPTF)
Flushing Ports (2) (1051C)	1/8" NPTF	(1/8" NPTF)
Discharge Ports (2)	1/2" NPTF	(1/2" NPTF)
Pulley Mounting	Either Side	(Either Side)
Shaft Diameter	1.181"	(30 mm)
Weight.....	44 lbs.	(19.9 kg)
Dimensions	16.28 x 12.99 x 6.44"	(413.50 x 330 x 163.50 mm)

ELECTRIC HORSEPOWER REQUIREMENTS

FLOW		PRESSURE			MOTOR PULLEY SIZE	
		PSI 1800	PSI 2000	PSI 2200	Using 1725 RPM Motor & Std. 10" Pump Pulley	
U.S. GPM	L/M	BAR 125	BAR 140	BAR 155	RPM	Pulley O.D.
12.0	45	14.8	N/A	N/A	1150	6.5
10.0	38	12.4	13.7	15.1	958	5.4
9.0	34	11.1	12.4	13.6	836	4.9

DETERMINING THE PUMP R.P.M.	<u>Rated G.P.M.</u>	=	<u>"Desired" G.P.M.</u>
	<u>Rated R.P.M.</u>	=	<u>"Desired" R.P.M.</u>
DETERMINING THE REQUIRED H.P.	<u>GPM x PSI</u>	=	Electric Brake
	1460	=	H. P. Required
DETERMINING MOTOR PULLEY SIZE	<u>Motor Pulley O.D.</u>	=	<u>Pump Pulley O.D.</u>
	<u>Pump R.P.M.</u>	=	<u>Motor R.P.M.</u>

See complete Drive Packages [Incls: Pulleys, Belts, Hubs, Key] Tech Bulletin 003. Refer to pump **Service Manual** for repair procedure, additional technical information and **pump warranty**.

"Customer confidence is our greatest asset"

PARTS LIST

ITEM	PART NUMBER		PART NUMBER		PART NUMBER		DESCRIPTION	QTY
	1050	MATL	1051	MATL	1057	MATL		
2	30067	STL	30067	STL	30067	STL	Key (M8x7.5x25))	1
5	92519	STZP	92538	S	92538	S	Screw, HHC Sems (M6x16)	8
	125824	STCP R	—	—	—	—	Screw, HHC, Sems (M6x16)	8
8	43496	AL	43496	AL	43496	AL	Cover, Bearing	2
9	815281	FBR	815281	FBR	815281	FBR	Shim, Split, Bearing Cover 2-Pc	2/4
	814800	S	814800	S	814800	S	Shim, Split, Bearing Cover 2-Pc	0/4
10	11340	NBR	11340	NBR	11340	NBR	O-Ring, Bearing Cover - 70D	2
11	43495	NBR	43495	NBR	43495	NBR	Seal, Oil, Crankshaft - 70D	2
15	39060	STL	39060	STL	39060	STL	Bearing, Roller	2
20	48600	TNM	48600	TNM	48600	TNM	Rod, Connecting Assembly [10/01]	3
25	43494	FCM	43494	FCM	43494	FCM	Crankshaft, Dual End	1
31	828710	—	828710	—	828710	—	Protector, Oil Cap w/Foam Gasket	1
32	43211	ABS	43211	ABS	43211	ABS	Cap, Oil Filler	1
33	14177	NBR	14177	NBR	14177	NBR	O-Ring, Filler Cap - 70D	1
37	92241	—	92241	—	92241	—	Gauge, Oil, Bubble w/Gasket - 80D	1
38	44428	NBR	44428	NBR	44428	NBR	Gasket, Flat, Oil Gauge - 80D	1
40	92520	STZP	92542	S	92542	S	Screw, HHC Sems (M6x20)	4
	126541	STCP R	—	—	—	—	Screw, HHC, Sems (M6x20)	4
48	25625	STCP	25625	STCP	25625	STCP	Plug, Drain (1/4"x19BSP)	1
49	23170	NBR	23170	NBR	23170	NBR	O-Ring, Drain Plug - 70D	1
50	43491	AL	43491	AL	43491	AL	Cover, Rear	1
51	44834	NBR	44834	NBR	44834	NBR	O-Ring, Rear Cover - 70D	1
53	115471	AL	115471	AL	115471	AL	Crankcase w/Guide Pins	1
54	27488	S	27488	S	27488	S	Pin, Guide	2
56	44664	POP	44664	POP	44664	POP	Pan, Oil	1
64	43507	CM	43507	CM	43507	CM	Pin, Crosshead	3
65	43501	SZZ	45258	SSZZ	45258	SSZZ	Rod, Plunger	3
69	126592	STCP R	126592	STCP R	126592	STCP R	Washer, Oil Seal	3
70	43500	NBR	43500	NBR	43500	NBR	Seal, Oil, Crankcase - 80D	3
75	43506	S	43506	S	43506	S	Slinger, Barrier	3
88	45675	S	45675	S	45675	S	Washer, Keyhole	3
89	43553	BB	45879	SS	45879	SS	Collar, Spacer	3
90	43552	CC	43552	CC	43552	CC	Plunger (M24x77)	3
95	—	SS	89651	SS	89651	SS	Stud, Plunger Retainer (M6x70)	3
96	43235	PTFE	43235	PTFE	43235	PTFE	Back-up-Ring, Plunger Retainer	3
97	17399	NBR	17399	NBR	17399	NBR	O-Ring, Plunger Retainer - 80D	3
	14160	FPM	14160	FPM	14160	FPM	O-Ring, Plunger Retainer - 70D	3
	46204	EPDM	46204	EPDM	46204	EPDM	O-Ring, Plunger Retainer - 70D	3
98	44041	SS	44041	SS	44041	SS	Gasket, Plunger Retainer	3
99	—	—	44031	SS	44031	SS	Retainer, Plunger (M6)	3
	104360	S	—	—	—	—	Retainer w/Stud	3
100	855001	POP	855001	POP	855001	POP	Retainer, Seal 2-Pc [07/05]	3
101	43554	—	43554	—	43554	—	Wick, Long Tab	3
106	44035	NBR	44035	NBR	44035	NBR	Seal, LPS w/SS-Spg	3
	44388	FPM	44388	FPM	44388	FPM	Seal, LPS w/SS-Spg	3
	46208	EPDM	46208	EPDM	46208	EPDM	Seal, LPS w/SS-Spg	3
120	49290	BB	49286	SSNP	49286	SSNP	Case, Seal [07/05]	3
121	14762	NBR	14762	NBR	14762	NBR	O-Ring, Seal Case - 70D	3
	11737	FPM	11737	FPM	11737	FPM	O-Ring, Seal Case - 75D	3
	46205	EPDM	46205	EPDM	46205	EPDM	O-Ring, Seal Case	3
126	43558	BB	48389	D	48389	D	Adapter, Female	3
	—	—	45073	SSL	45073	SSL	Adapter, Female	3
127	43559	SNG	103692	STG*	103692	STG*	V-Packing	6
128	43560	BB	45074	SSL	45074	SSL	Adapter, Male	3
139	20326	BBCP	44382	SS	44562	NAB	Plug, Inlet (3/4" NPT)	1
162	43248	PTFE	43248	PTFE	43248	PTFE	Back-up-Ring, Valve Seat	6
163	43249	NBR	43249	NBR	43249	NBR	O-Ring, Seat - 80D	6
	44383	FPM	44383	FPM	44383	FPM	O-Ring, Seat - 70D	6
	46206	EPDM	46206	EPDM	46206	EPDM	O-Ring, Seat - 70D	6
164	44718	S	44037	SS	44037	SS	Seat	6
166	43721	S	48793	SSL	48793	SSL	Valve	6
167	43751	S	44039	SS	44039	SS	Spring, Valve	6
168	44564	PVDF	44564	PVDF	44564	PVDF	Retainer, Spring	6
171	—	—	—	—	44832	S	Coil Spring, Valve Plug	6
172	17617	NBR	17617	NBR	17617	NBR	O-Ring, Valve Plug - 90D	6
	11691	FPM	11691	FPM	11691	FPM	O-Ring, Valve Plug - 90D	6
	46207	EPDM	46207	EPDM	46207	EPDM	O-Ring, Valve Plug - 70D	6
174	43851	BBCP	49293	SS	44831	NAB	Plug, Valve	6
185	46704	BBCP	48726	SS	46706	NAB	Head, Manifold [9/00]	1
	—	—	49188	SS	—	—	Head, Manifold, Flushed (1/8" Flushed Port) 1051C ONLY	1
187	126545	STCP R	44005	S	44005	S	Stud, Manifold (M10x45)	4
192	12503	STZP	15847	S	15847	S	Lockwasher (M10)	4
	126231	STCP R	—	—	—	—	Lockwasher (M10)	4
194	126522	STCP R	81258	S	81258	S	Nut, Hex (M10)	4
250	30764	NY	30764	NY	30764	NY	Protector, Shaft w/2 Screws	1
255	30264	STZP	30264	STZP	30264	STZP	Mounting, Direct	1
260	30613	STZP	30613	STZP	30613	STZP	Mount, Rail, Assy	1
265	30661	—	30661	—	30661	—	Kit, Complete Mounting, U.S. (Incls: 30613, 30206, 30059, 30067, 30764)	1
269	30206	F	30206	F	30206	F	Pulley (10") AB [See Drive Packages, Tech Bulletin 003]	1
274	30059	STL	30059	STL	30059	STL	Hub, "H", M30 (Keyway M8) [See Drive Packages, Tech Bulletin 003]	1
283	34334	—	34334	—	34334	—	Kit, Oil Drain	1

EXPLODED VIEW

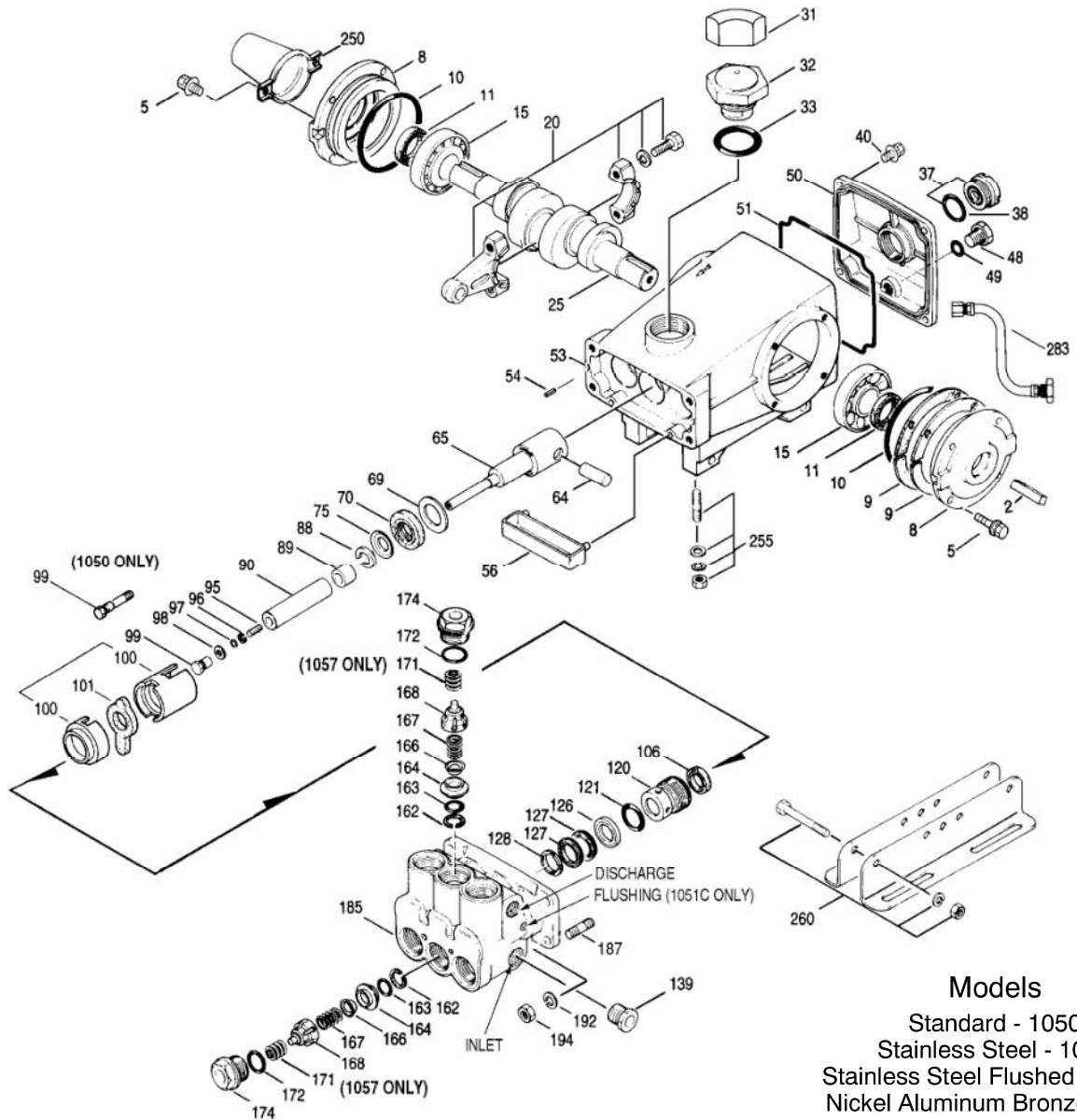

Models
 Standard - 1050
 Stainless Steel - 1051
 Stainless Steel Flushed - 1051C
 Nickel Aluminum Bronze - 1057
 July 2008

	1050	MATL	1051	MATL	1057	MATL		
290	—	—	6124	—	6124	—	Gasket, Liquid (3 oz.)	1
299	814560	BBCP	816771	SS	815261	NAB	Head, Complete [9/00]	1
	—	—	818333	SS	—	—	Head, Complete - C (1051C Only)	1
300	30913	NBR	33916	NBR*	33916	NBR*	Kit, Seal (Incls: 97, 100, 106, 121, 127)	1
	30986	FPM*	30986	FPM*	30986	FPM*	Kit, Seal (Incls: 97, 100, 106, 121, 127)	1
	◆ 33913	EPDM*	◆ 33913	EPDM*	◆ 33913	EPDM*	Kit, Seal (Incls: 97, 100, 106, 121, 127)	1
310	34920	NBR	34387	NBR	34387	NBR	Kit, Valve (Incls: 162, 163, 164, 166, 167, 168, 172)	2
	31256	FPM	30987	FPM	30987	FPM	Kit, Valve (Incls: 162, 163, 164, 166, 167, 168, 172)	2
	◆ 31253	EPDM	◆ 31258	EPDM	◆ 31258	EPDM	Kit, Valve (Incls: 162, 163, 164, 166, 167, 168, 172)	2
350	30696	STZP	30696	STZP	30696	STZP	Plier, Reverse	1
351	43523	STZP	43523	STZP	43523	STZP	Tool, Seal Case Removal	1
—	711500	SS	711500	SS	711500	SS	C.A.T. (Inlet pressure stabilizer for RO and boosted inlet applications)	1
—	711503	SS	711503	SS	711503	SS	Adapter (2 per C.A.T.) (See Data Sheet for complete selection)	2
—	6575	—	6575	—	6575	—	Plunger Pump Service DVD	1
—	6107	—	6107	—	6107	—	Oil, Bottle (21 oz) ISO 68 Multi-viscosity Hydraulic (Fill to specified crankcase capacity prior to start-up)	2
—	—	—	6119	—	—	—	Lubricant, Antiseize (1 oz.)	1

Bold print part numbers are unique to a particular pump model. Italics are optional items. [] Date of latest production change.

◆ Silicone oil/grease required. † Production parts are different than service parts. R components comply with RoHS Directive.

*Review material codes for individual items (STG generally may be used as an alternate).

See Tech Bulletins 002, 003, 024, 027, 035, 036, 043, 045, 046, 048, 049, 052, 053, 072, 074, 077, 083, 087, 089 and 098 for additional information.

MATERIAL CODES (Not Part of Part Number): ABS=ABS Plastic AL=Aluminum BB=Brass BBCP=Brass/Chrome Plated CC=Ceramic CM=Chrome-moly D=Acetal EPDM=Ethylene Propylene Diene Monomer F=Cast Iron FBR=Fiber FCM=Forged Chrome-moly FPM=Fluorocarbon NAB=Nickel Aluminum Bronze NBR=Medium Nitrile (Buna-N) NY=Nylon POP=Polypropylene PTFE=Pure Polytetrafluoroethylene PVDF=Polyvinylidene Fluoride S=304SS SNG=Special Blend (Buna) STG=Special Blend PTFE White SS=316SS SSL=316SS/Low Carbon SSZZ=316SS/Zamak STCP=Steel/Chrome Plated SSNP=316SS/Nickel Plated STL=Steel STZP=Steel/Zinc Plated SZZ=304SS/Zamak TNM=Special High Strength

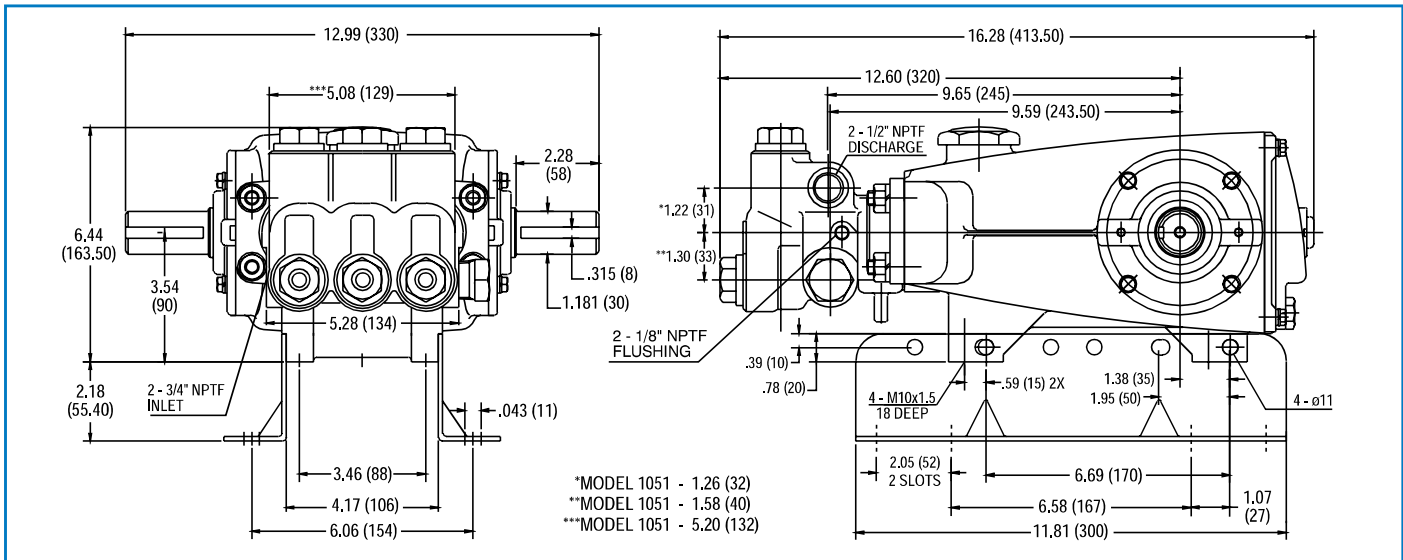

Models 1050, 1051, 1051C, 1057

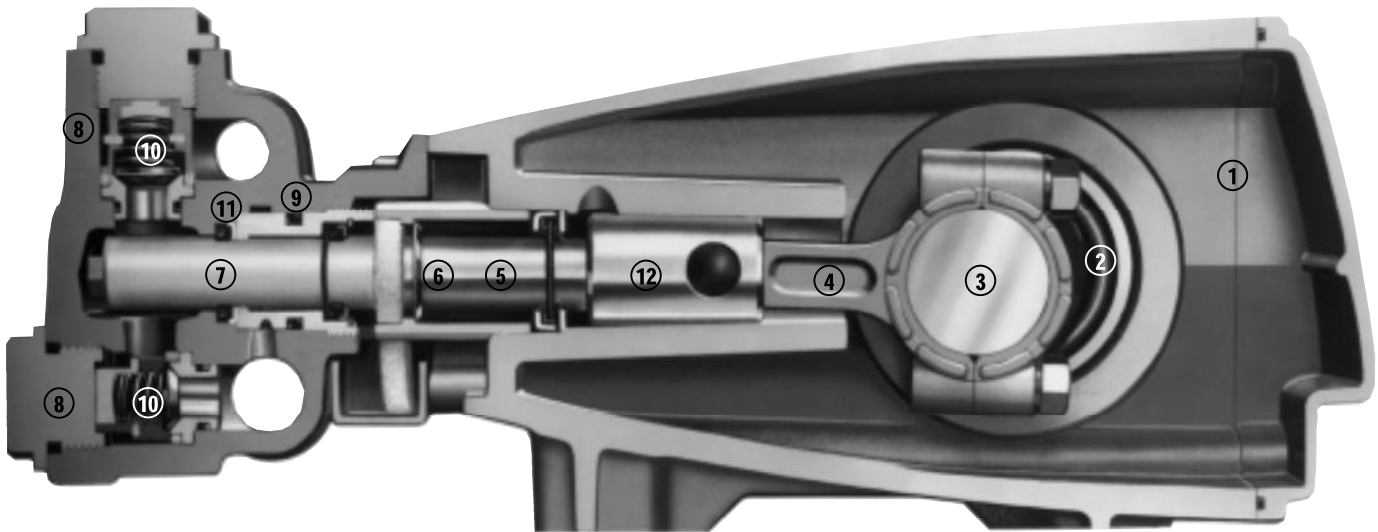

- 1 Die cast aluminum **crankcase** means high strength, lightweight, and excellent tolerance control.
- 2 Oversized crankshaft **bearings** provide extended bearing life and pump performance.
- 3 Chrome-moly **crankshaft** provides unmatched strength and surface hardness for long life.
- 4 Matched oversized TNM **connecting rods** noted for superior tensile strength and bearing quality.
- 5 The **plunger rods** are high tensile strength stainless steel with Zamak crossheads.
- 6 The stainless steel **slinger** provides back-up protection for the crankcase seal, keeping pumped liquids out of the crankcase.
- 7 Special concentric, high-density, polished, solid ceramic **plungers** provide a true wear surface and extended seal life.
- 8 **Manifolds** are a high tensile strength forged brass, stainless steel or nickel aluminum bronze for long term, continuous duty.
- 9 100% wet **seal** design adds to service life by allowing pumped liquids to cool and lubricate on both sides.
- 10 Stainless steel **valves, seats and springs** provide corrosion-resistance, ultimate seating and extended life.
- 11 Specially formulated, CAT PUMP exclusive, **V-Packings** offer unmatched performance and seal life.
- 12 **Crossheads** are 360° supported for uncompromising alignment.
- 13 Special **ported inlet manifold** permits an external flush liquid providing cooling for hi-temp liquids and lubrication for low lubricity liquids. (Not Shown)

Products described herein are covered by one or more of the following U.S. patents 3558244, 3652188, 3809508, 3920356, 3930756 and 5035580

World Headquarters
CAT PUMPS
 1681 - 94th Lane N.E. Minneapolis, MN 55449-4324
 Phone (763) 780-5440 — FAX (763) 780-2958
 e-mail: techsupport@catpumps.com
 www.catpumps.com

International Inquiries
 FAX (763) 785-4329
 e-mail: intlsales@catpumps.com



CAT PUMPS (U.K.) LTD.
 1 Fleet Business Park, Sandy Lane, Church Crookham
 FLEET, Hampshire, GU52 8BF, England
 Phone Fleet 44 1252-622031 — Fax 44 1252-626655
 e-mail: sales@catpumps.co.uk www.catpumps.co.uk

N.V. CAT PUMPS INTERNATIONAL S.A.
 Heiveldkens 6A, B-2550 Kontich, Belgium
 Phone 32-3-450.71.50 — Fax 32-3-450.71.51
 e-mail: cpi@catpumps.be www.catpumps.be

CAT PUMPS DEUTSCHLAND GmbH
 Buchwiese 2, D-65510 Idstein, Germany
 Phone 49 6126-9303 0 — Fax 49 6126-9303 33
 e-mail: catpumps@t-online.de www.catpumps.de

5, 7, 15PFR PLUNGER PUMP SERVICE MANUAL



5 FRAME: 310, 340, 350, 311, 341, 351, 317, 347, 357

5 FRAME OEM: 30, 31, 34, 35, 42HS, 43HS, 45

7 FRAME: 530, 550

7 FRAME OEM: 51, 53, 55, 56, 57, 58, 59, 60, 70

15 FRAME: 650, 651, 660, 661, 1050, 1051, 1057

INSTALLATION AND START-UP INFORMATION

Optimum performance of the pump is dependent upon the entire liquid system and will be obtained only with the proper selection, installation of plumbing and operation of the pump and accessories.

SPECIFICATIONS: Maximum specifications refer to individual attributes. It is not implied that **all maximums** can be performed **simultaneously**. If more than one maximum is considered, check with your CAT PUMPS supplier to confirm the proper performance and pump selection. Refer to individual pump Data Sheets for complete specifications, parts list and exploded view.

LUBRICATION: Fill crankcase with special CAT PUMP oil per pump specifications [5PFR-18 oz., 7PFR-25 oz., 15PFR-42oz.]. **DO NOT RUN PUMP WITHOUT OIL IN CRANKCASE.** Change initial fill after 50 hours running period. Thereafter, change oil every **3 months or 500 hour intervals**, whichever comes first.

PUMP ROTATION: Pump was designed for forward rotation to allow optimum lubrication of the crosshead area. Reverse rotation is acceptable if the crankcase oil level is increased slightly above center dot to assure adequate lubrication.

PULLEY SELECTION: Select size of motor pulley required to deliver the desired flow from Horsepower Requirement and Pulley Selection Chart (refer to Tech Bulletin 003 or individual Data Sheet).

DRIVE SELECTION: The motor or engine driving the pump must be of adequate horsepower to maintain full RPM when the pump is under load. Select the electric motor from the Horsepower Requirement Chart according to required pump discharge flow, maximum **pressure at the pump** and drive losses of approximately 3-5%. Consult the manufacturer of gas or diesel engine for selection of the proper engine size.

MOUNTING: Mount the pump on a rigid, horizontal surface in a manner to permit drainage of crankcase oil. An uneven mounting surface will cause extensive damage to the pump base. To minimize piping stress, **use appropriate flexible hose to inlet and discharge ports.** Use the correct belt; make sure pulleys are aligned. Excessive belt tension may be harmful to the bearings. Hand rotate pump before starting to be certain shaft and bearings are free moving.

LOCATION: If the pump is used in extremely dirty or humid conditions, it is recommended pump be enclosed. Do not store or operate in excessively high temperature areas or without proper ventilation.

INLET CONDITIONS: Refer to complete **Inlet Condition Check-List** in this manual before starting system. **DO NOT STARVE THE PUMP OR RUN DRY.** Temperatures above 130°F are permissible. Add 1/2 PSI inlet pressure per each degree F over 130°F. Elastomer or RPM changes may be required. See Tech Bulletin 002 or call CAT PUMPS for recommendations.

C.A.T.: Installation of a C.A.T. (Captive Acceleration Tube) is recommended in applications with stressful inlet conditions such as high temperatures, booster pump feed, long inlet lines or quick closing valves.

DISCHARGE CONDITIONS: **OPEN ALL VALVES BEFORE STARTING SYSTEM** to avoid deadhead overpressure condition and severe damage to the pump or system.

Install a **Pulsation Dampening** device on the discharge head or in the discharge line as close to the head as possible. Be certain the pulsation dampener (Prrrrr-o-lator) is properly precharged for the system pressure (see individual Data Sheet).

A **reliable Pressure Gauge** should be installed near the discharge outlet of the high pressure manifold. This is extremely important for adjusting pressure regulating devices and also for proper sizing of the nozzle or restricting orifice. The pump is rated for a maximum pressure; this is the **pressure that is read at the discharge manifold of the pump, NOT AT THE GUN OR NOZZLE.**

Use PTFE thread tape or pipe thread sealant (sparingly) connect accessories or plumbing. Exercise caution not to wrap tape beyond the last thread to avoid tape from becoming lodged in the pump or accessories. This condition will cause a malfunction of the pump or system.

PRESSURE REGULATION: All systems require both a primary pressure regulating device (i.e., regulator, unloader) and a secondary pressure safety relief device (i.e., pop-off valve, safety valve). The primary pressure device must be installed on the discharge side of the pump. The function of the primary pressure regulating device is to protect the pump from over pressurization, which can be caused by a plugged or closed off discharge line. Over pressurization can severely damage the pump, other system components and can cause bodily harm. The secondary safety relief device must be installed between the primary device and pump. This will ensure pressure relief of the system if the primary regulating device fails. Failure to install such a safety device will void the warranty on the pump.

When the high pressure system is left running with the trigger gun off, the by-pass liquid can be routed to drain or to the pump inlet. If routed to the pump inlet, the **by-pass liquid can quickly develop excessive heat and result in damage to the pump.** A THERMO VALVE installed in the by-pass line is recommended to protect the pump. An AUTO SHUT-OFF ASSEMBLY may also be used.

NOZZLES: A worn nozzle will result in loss of pressure. Do not adjust pressure regulating device to compensate. Replace nozzle and reset regulating device to system pressure.

PUMPED LIQUIDS: Some Liquids may require a **flush between operations or before storing.** For pumping liquids other than water, contact your CAT PUMPS supplier.

STORING: For extended storing or between use in cold climates, drain all pumped liquids from pump and **flush with antifreeze solution to prevent freezing and damage to the pump.** **DO NOT RUN PUMP WITH FROZEN LIQUID** (refer to Tech Bulletin 083).

WARNING

All systems require both a primary pressure regulating device (i.e., regulator, unloader) and a secondary pressure safety relief device (i.e., pop-off valve, safety valve). Failure to install such relief devices could result in personal injury or damage to the pump or to system components. CAT PUMPS does not assume any liability or responsibility for the operation of a customer's high pressure system.

Products described hereon are covered by one or more of the following U.S. patents 3558244, 3652188, 3809508, 3920356, 3930756 and 5035580

World Headquarters

CAT PUMPS

1681 - 94th Lane N.E. Minneapolis, MN 55449-4324

Phone (763) 780-5440 — FAX (763) 780-2958

e-mail: techsupport@catpumps.com

www.catpumps.com

International Inquiries

FAX (763) 785-4329

e-mail: intlsales@catpumps.com



The Pumps with Nine Lives

CAT PUMPS (U.K.) LTD.

1 Fleet Business Park, Sandy Lane, Church Crookham, Fleet

Hampshire GU52 8BF, England

Phone Fleet 44 1252-622031 — Fax 44 1252-626655

e-mail: sales@catpumps.co.uk

N.V. CAT PUMPS INTERNATIONAL S.A.

Heiveldekens 6A, 2550 Kontich, Belgium

Phone 32-3-450.71.50 — Fax 32-3-450.71.51

e-mail: cpi@catpumps.be www.catpumps.be

CAT PUMPS DEUTSCHLAND GmbH

Buchwiese 2, D-65510 Idstein, Germany

Phone 49 6126-9303 0 — Fax 49 6126-9303 33

e-mail: catpumps@t-online.de www.catpumps.de

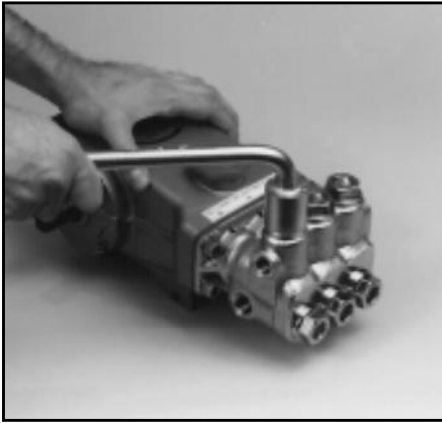

Removal of Valve Plugs

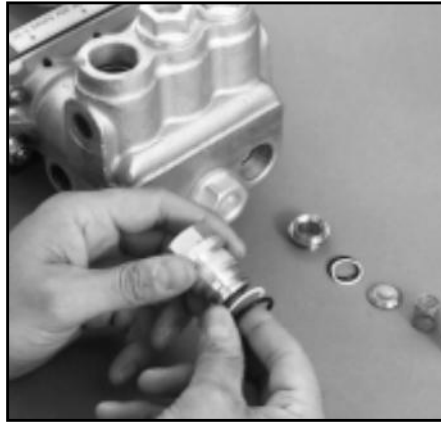

Examination of O-Ring and Back-up-Ring on Valve Plug

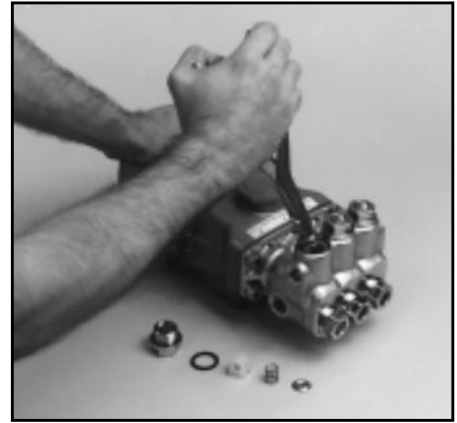

Removal of Valve Assembly

CAUTION: Before commencing with service, shut off drive (electric motor, gas or diesel engine) and turn off water supply to pump. Relieve all discharge line pressure by triggering gun or opening valve in discharge line.

After servicing is completed, turn on water supply to pump, start drive, reset pressure regulating device and secondary valve, read system pressure on the gauge at the pump head. Check for any leaks, vibration or pressure fluctuations and resume operation.

SERVICING THE VALVES

Disassembly

NOTE: Usually the valve assembly will remain together while being removed.

1. Remove the hex Valve Plugs (top discharge, bottom inlet).
2. Examine the O-Ring under the Valve Plug for cuts or distortion and replace if worn. Lubricate new O-Rings before installing.

NOTE: On Models 43HS, 45, 56, 57, 59, 60, 70 there is an extended Valve Plug with O-Ring and Back-up-Ring. Install the Back-up-Ring, then the O-Ring into the groove at the end of the Valve Plug (refer to Tech Bulletin 058).

3. Grasp Spring Retainer by tab at the top with pliers and remove from valve chamber.
4. To separate the valve assembly, insert a screwdriver into the side of the Retainer and press on the back side of the Valve to begin separation, then between the Retainer and Valve Seat to separate completely.
5. If the valve assembly separates during removal, remove the Spring and Valve with a needle nose pliers.
6. Using a reverse pliers, remove the Valve Seat from the manifold chamber.

Reassembly

1. Examine Spring Retainers for internal wear or breaks in the structure and replace as needed.
2. Examine Springs for fatigue or breaks and replace as needed.
3. Examine Valves and Seats for grooves, pitting or wear and replace as needed.
4. Examine Seat and Valve Plug O-Rings for cuts or wear and replace as needed. Lubricate and install new O-Ring onto outside diameter of Seat and Valve Plugs.

NOTE: Inlet and discharge valve parts are interchangeable. Two Valve Kits are needed for complete valve change.

5. Grasp new Valve Assembly by tab at top with pliers and push into valve chamber. Be certain Valve Assembly is completely seated in valve chamber.

NOTE: For certain applications apply liquid gasket to the O-Ring crevices and seal surfaces (refer to Tech Bulletin 053).

NOTE: For Corrosion Resistant Models remember to install the Coil Spring between the Valve Plug and Retainer (refer to Tech Bulletin 046).

6. Apply Loctite 242 to the threads of the Valve Plug, thread into manifold port and torque per chart.

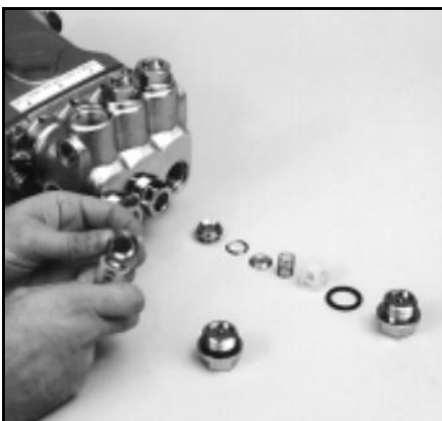

Order of parts in Valve Assembly

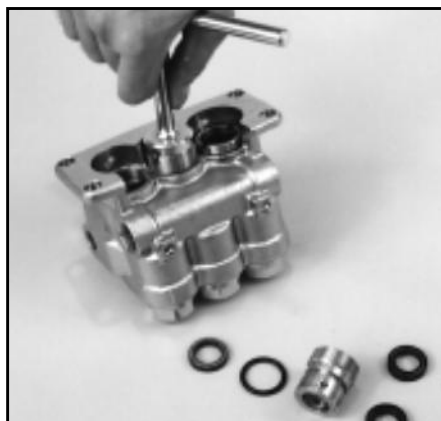

Removal of Seal Cases from Manifold Head

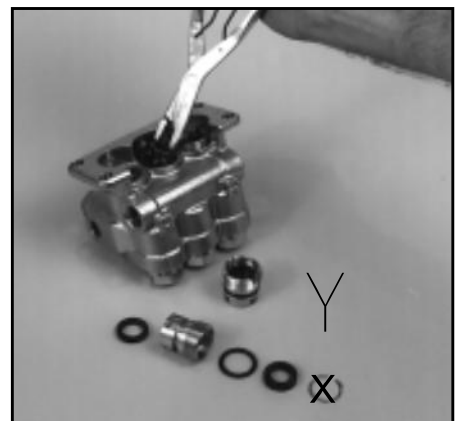

Removal of High Pressure Seals

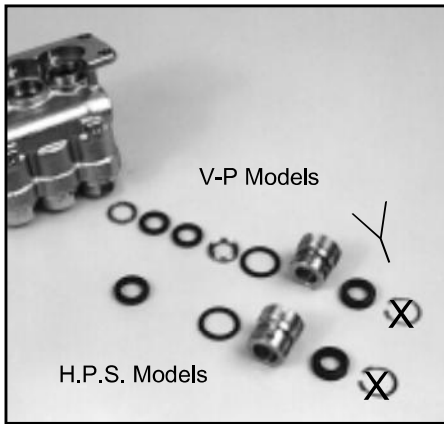

Seal and V-Packing Arrangement



Installation of Male Adapter



Order of Packings [MA, VP, FA]

SERVICING THE SEALS

Disassembly

1. Remove the Manifold Head as described in SERVICING THE PLUNGERS section.
2. Place Manifold Head on work surface **with crankcase side up**.
3. On 5PFR and 7PFR plunger pumps prior to May of 1989, remove Snap Ring and Lo-Pressure Seal from each Seal Case. Discard Snap Rings (refer to Tech Bulletin 054).
4. On 5PFR and 7PFR plunger pumps after May of 1989, remove Lo-Pressure Seal from each Seal Case.
5. On 15PFR plunger pumps, remove Snap Ring and Lo-Pressure Seal from each Seal Case.
6. Remove Seal Case from each seal chamber. Remove O-Ring from outside diameter of Seal Case.
7. **Hi-Pressure Seal Models:** The Hi-Pressure Seal is generally easily removed from the manifold without any tools. If extremely worn a reverse pliers may be used.
8. **V-Packing Models:** The Female Adapter, V-Packings and Male Adapter are easily removed from manifold without any tools. If extremely worn a reverse pliers may be used.

Reassembly

V-Packing Models:

1. Lubricate seal chamber in the manifold.
 - NOTE: For certain applications apply liquid gasket to the O-Ring crevices and seal surfaces (refer to Tech Bulletin 053).**
2. Insert Male Adapter **with notches down and "v" side up** and press completely into chamber by hand.
3. Lubricate V-Packings and install one at a time with **grooved side down**.
4. Install Female Adapter with **grooved side down**.
5. Examine Seal Case O-Ring and replace if worn. Lubricate new O-Rings before installing.
6. Thread Seal Case into manifold and tighten with special seal case tool. Torque per chart.

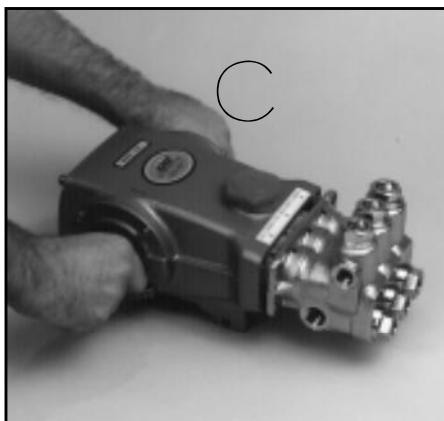

Separating Manifold Head from Crankcase

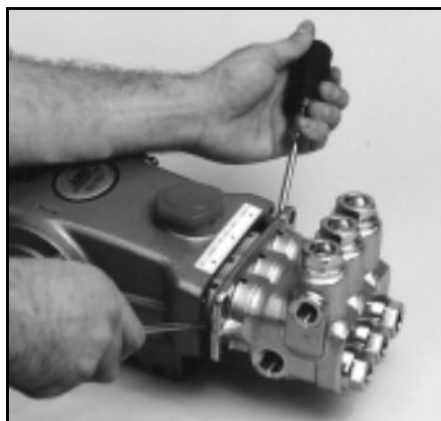

Removal of Manifold Head from Crankcase

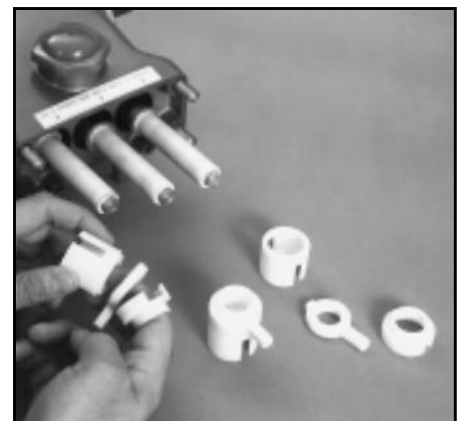

Removal of Seal Retainers and Wicks

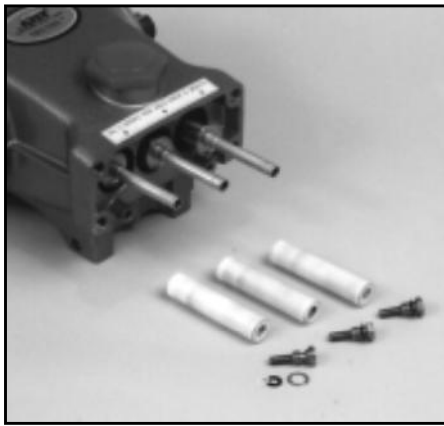

Ceramic Plunger and Retainer Arrangement



Proper Alignment of Ceramic Plungers for reassembly

Hi-Pressure Seal Models:

1. Lubricate seal chamber in manifold.

NOTE: For certain applications apply liquid gasket to the O-Ring crevices and seal surfaces (refer to Tech Bulletin 053).

2. Carefully square Hi-Pressure Seal into position by hand with the **grooved side down** (metal back facing out).

NOTE: When alternate materials, the fit of the special materials may be snug and require gently driving the LPS into position with a cylinder of the same diameter to assure a square seating and no damage to the LPS.

3. Examine Seal Case O-Ring and replace if worn. Lubricate new O-Ring before installing.
4. Secure Hi-Pressure Seal into position by threading Seal Case into manifold. Tighten Seal Case with special seal case tool. Torque per chart.

Lo-Pressure Seal - All Models:

1. Examine Lo-Pressure Seals for wear or broken springs and replace if necessary.
2. Install Lo-Pressure Seal into each seal case with **garter spring down**.
3. On 5PFR and 7PFR plunger pumps **do not use** Snap Ring (refer to Tech Bulletin 054).
4. On 15PFR plunger pumps **install Snap Ring** into each Seal Case.
5. Install the Seal Retainer with new Wick onto each plunger rod **with tab down and wick out**.
6. Rotate Crankshaft by hand so the two outside plungers are extended equally.
7. Lightly lubricate the Ceramic Plunger, then carefully slide the Manifold Head over the Ceramic Plunger, supporting it from the underside to avoid damage to the plungers or seals. Press the Manifold Head into the Crankcase until flush.
8. Replace two (2) Lockwashers, two (2) Socket Head Screws for (4) Flange Nuts and torque per chart.

SERVICING THE PLUNGERS

Disassembly

1. Using an M8 allen wrench on the 5PFR pumps, a M14 hex tool on the 7PFR pumps, or a M17 hex tool on the 15PFR pumps, remove the two (2) Socket Head Screws, and two (2) Lockwashers or four (4) Flanged Nuts.
2. Rotate Crankshaft by hand to start separation of Manifold head from Crankcase.
3. Insert two flat head screwdrivers on opposite sides to further separate Manifold Head from Crankcase or support the underside of the Manifold Head and tap lightly with a mallet on the backside of the Manifold Head.

CAUTION: KEEP MANIFOLD PROPERLY ALIGNED WITH CERAMIC PLUNGERS WHEN REMOVING TO AVOID DAMAGE TO EITHER PLUNGERS OR SEALS.

4. Remove Oil Pan and slide out Seal Retainer with Wick.
5. Using an M12 hex tool on the 5, 7 and 15PFR pumps, or an M11 hex tool on the OEM 5, and 7PFR pumps, loosen the Plunger Retainer about three to four turns.
6. Push the Ceramic Plunger back towards the Crankcase to separate it from the Plunger Retainer and proceed with unthreading the Plunger Retainer by hand.
7. Remove the Plunger Retainer, O-Ring, Back-up-Ring and Gasket. Stud may stay on Plunger Rod or come off with Plunger Retainers.
8. Remove the Ceramic Plunger, Keyhole Washer and Barrier Slinger from Plunger Rod.

Reassembly

1. Visually inspect Crankcase Oil Seals for deterioration or leaks. Contact CAT PUMPS for assistance with replacement. See SERVICING THE CRANKCASE section.
2. Examine Barrier Slings and Keyhole Washers for damage. Slide onto Plunger Rod **with concave side away from Crankcase**.
3. Examine Ceramic Plunger for scoring, scale build-up, chips or cracks and replace as needed.
4. Slide Ceramic Plunger over each Plunger Rod.

NOTE: Ceramic Plunger can only be installed in one direction (front to back). Do not force onto rod.
5. Examine O-Ring and Back-up-Ring on Plunger Retainer and replace if cut or worn. Lubricate O-Rings for ease of installation and to avoid damage to the O-Rings.

6. Install new Gasket, then O-Ring, then Back-up-Ring onto each Plunger Retainer.

NOTE: OEM models have a longer Plunger Retainer Stud.

7. Apply Loctite 242 to exposed threads of Stud and thread Plunger Retainer onto Plunger Rod. Torque per chart.
8. Install the seal Retainer with NEW Wick onto each rod with **tab down and wick out.**

NOTE: Do not lubricate wicks at initial start-up. Operate for 10 to 15 minutes to allow grease from LPS to penetrate the plunger surface, then lubricate as needed.

9. Rotate Crankshaft by hand so the two outside plungers are extended equally.
10. Lightly lubricate the Ceramic Plungers, then carefully slide the Manifold Head over the Ceramic Plungers supporting it from the underside to avoid damage to the Ceramic Plungers or Seals. On the high pressure V-Packing models or larger manifolds, it may be necessary to gently tap with a soft mallet until the manifold is flush with the crankcase.
11. Replace two (2) Lockwashers, two (2) Socket Head Screws or four (4) Flanged Nuts and torque per chart.

SERVICING THE CRANKCASE SECTION

1. While Manifold, Plungers and Seal Retainers are removed, examine Crankcase Oil Seals for leaking and wear.
2. Check for any signs of leaking at Bearing Covers, Rear Cover, Drain Plug or Bubble Gauge.
3. Check oil level and for evidence of water in oil.
4. Rotate Crankshaft by hand to feel for smooth bearing movement.
5. Examine Crankshaft Oil Seals externally for drying, cracking or leaking.
6. Consult CAT PUMPS or your local distributor if crankcase service is evidenced.

See Section I of the Plunger Pump Service Video for additional information.

PREVENTATIVE MAINTENANCE CHECK-LIST

Check	Daily	Weekly	50 hrs.	500 hrs.*	1500 hrs.**	3000 hrs.**
Clean Filters	x					
Oil Level/Quality	x					
Oil Leaks	x					
Water Leaks	x					
Belts, Pulley		x				
Plumbing		x				
Initial Oil Change			x			
Oil Change				x		
Seal Change					x	
Valve Change						x
Accessories					x	

* If other than CAT PUMPS special multi-viscosity ISO68 oil is used, change cycle should be every 300 hours.

** Each system's maintenance cycle will be exclusive. If system performance decreases, check immediately. If no wear at 1500 hours, check again at 2000 hours and each 500 hours until wear is observed. Valves typically require changing every other seal change.

Duty cycle, temperature, quality of pumped liquid and inlet feed conditions all effect the life of pump wear parts and service cycle.

** Remember to service the regulator/unloader at each seal servicing and check all system accessories and connections before resuming operation. Refer to video for additional assistance.

TECHNICAL BULLETIN REFERENCE CHART

No.	Subject	Models
003	Power Unit Drive Packages	3PFR - 68PFR, 10FR - 60FR
024	Lubrication of Lo-Pressure Seals	All Models
027	Spring Retainer	5PFR, 7PFR, 15PFR
032	Shaft Extension and Manifold Port	310, 317, 323, 530, 550
035	Servicing Crankcase Section	7PFR - 60PFR
036	Cylinder and Plunger Reference Chart	All Models
043	LPS and HPS Servicing	All Plunger Models
045	One-Piece S.S. Plunger Retainer w/Stud	5PFR, 7PFR, 15PFR
046	Valve Plug with Coil Spring	317, 347, 357, 1057
047	Blind Bearing Shaft Cover	Gearbox Plunger Pumps
048	Extended Valve Plug	7PFR and 15PFR
049	Stainless Steel Hardware	3PFR7, 5PFR7, 15PFR7
051	M10 Manifold and Crankcase	7PFR and OEM
052	Plunger Rod and Stud	3PFR, 5PFR, 15PFR, 35PFR, 60PFR
053	Liquid Gasket	All Plunger NAB-S.S. Models
054	2 Piece Seal Retainer	5PFR and 7PFR
058	Forged Manifold and Extended Valve Plugs	56, 57, 59, 60
060	Baffle Assembly	34170
061	Installation and Adjustment Procedure	8100
062	Manifold and Seal Case	650 and 651
064	By-Pass Hose Sizing	All Unloaders/Regulators
067	S.S. Plunger Retainer	3PFR, 5PFR, 7PFR
072	Manifold Head and V-Packing	1050, 1051, 1057
073	Hi-Temp HPS	3PFR, 5PFR, 2SF
074	Torque Chart	Piston and Plunger Pumps
077	Oil Drain Kit	All Models (except 2SF/4SF)
083	Winterizing a Pump	All Models

TORQUE CHART

Pump Item			Torque		
Pump Model	Thread	Tool Size [P/N]	in. lbs.	ft. lbs.	Nm
PLUNGER RETAINER					
OEM Models	M6	M11 Hex [44044]	55	4.4	6
All Standard Models	M6	M12 Hex	55	4.4	6
MANIFOLD HEAD BOLTS					
5PFR 30, 31, 34, 35.....	M10	M8 Allen [25052]	220	18.1	25
310, 340, 350 311, 341, 351 317, 347, 357					
5PFR 42HS, 43HS, 45.....	M10	M8 Allen [33046]	220	18.1	25
7PFR 510, 530, 550.....	M10	M14 Hex [25053]	220	18.1	25
56, 57, 58, 59, 60, 70					
15PFR 650, 651, 660, 661	M10	M17 Hex [25083]	220	18.1	25
1050, 1051, 1057					
VALVE PLUGS					
5PFR 30, 31, 34, 35.....	M22	M24 Hex [44046]	870	72.3	98
310, 311, 317 340, 341, 347 350, 351, 357 42HS					
5PFR 43HS, 45.....	M25	M24 Hex [44046]	520	43.4	59
7PFR 530, 550	3/4" SPT	M27 Hex [44045]	870	72.3	98
51, 55, 56, 57, 58 59, 60, 70					
15PFR 650, 651, 660, 661	3/4" SPT	M27 Hex [44045]	870	72.3	98
1050, 1051, 1057					
CRANKCASE COVER/ BEARING COVER SCREWS					
5PFR 30, 31, 34, 35.....	M6	M10 Hex/Phil. [25082]	50	4.0	6
310, 340, 350 317, 347, 357 311, 341, 351					
5PFR 42HS, 43HS, 45.....	M6	M10 Hex/Phil. [25082]	50	4.0	6
.....	M8	M13 Hex [25324]	115	9.4	13
7PFR 51, 53, 55, 56, 57.....	M6	M10 Hex [25082]	115	9.4	13
59, 60, 70					
15PFR 650, 1050.....	M6	M10 Hex [25082]	50	4.0	5.7
SEAL CASE					
5PFR 30, 31, 34, 35	N/A	1/2" Soc. Drive [33004]	354	29.5	40
310, 311, 317 340, 341, 347 350, 351, 357 42HS, 43HS, 45	N/A	1/2" Soc. Drive [33005]	354	29.5	40
7PFR 51, 53, 55, 56,	N/A	1/2" Soc. Drive [33005]	354	29.5	40
57, 58, 59, 60, 70 530, 550					
15PFR 650, 651, 660, 661	N/A	1/2" Soc. Drive [33006]	346	28.8	39
1050, 1051, 1057	N/A	1/2" Soc. Drive [33006]	390	32.5	44
BUBBLE OIL GAUGE					
All Models.....	M28	Oil Gauge Tool [44050]	45	3.6	5
MOUNTING BOLTS					
5PFR, 7PFR	M8	M13 Hex [25324]	115	9.4	13
15PFR	M10	M17 Hex [25083]	240	19.7	29

INLET CONDITION CHECK-LIST

Review Before Start-Up

Inadequate inlet conditions can cause serious malfunctions in the best designed pump. Surprisingly, the simplest of things can cause the most severe problems or go unnoticed to the unfamiliar or untrained eye. REVIEW THIS CHECK-LIST BEFORE OPERATION OF ANY SYSTEM. Remember, no two systems are alike, so there can be no **ONE** best way to set-up a system. All factors must be carefully considered.

INLET SUPPLY should exceed the maximum flow being delivered by the pump to assure proper performance.

- Open inlet shut-off valve and turn on water supply to avoid starving the pump. **DO NOT RUN PUMP DRY.**
- Temperatures above 130°F are permissible. Add 1/2 PSI inlet pressure per each degree F over 130°F. Elastomer or RPM changes may be required. See Tech Bulletin 002 or call CAT PUMPS for recommendations.
- Avoid closed loop systems especially with high temperature, ultra-high pressure or large volumes. Conditions vary with regulating/unloader valve.
- Low vapor pressure liquids, such as solvents, require a booster pump and C.A.T. to maintain adequate inlet supply.
- Higher viscosity liquids require a positive head and a C.A.T. to assure adequate inlet supply.
- Higher temperature liquids tend to vaporize and require positive heads and C.A.T. to assure adequate inlet supply.
- When using an inlet supply reservoir, size it to provide adequate liquids to accommodate the maximum output of the pump, generally a minimum of 6-10 times the GPM (however, a combination of system factors can change this requirement); provide adequate baffling in the tank to eliminate air bubbles and turbulence; install diffusers on all return lines to the tank.

INLET LINE SIZE should be adequate to avoid starving the pump.

- Line size must be a minimum of one size larger than the pump inlet fitting. Avoid tees, 90 degree elbows or valves in the inlet line of the pump to reduce the risk of flow restriction and cavitation.
- The line **MUST** be a FLEXIBLE hose, NOT a rigid pipe, and reinforced on SUCTION systems to avoid collapsing.
- The simpler the inlet plumbing the less the potential for problems. Keep the length to a minimum, the number of elbows and joints to a minimum (ideally no elbows) and the inlet accessories to a minimum.
- Use pipe sealant to assure air-tight, positive sealing pipe joints.

INLET PRESSURE should fall within the specifications of the pump.

- Acceleration loss of liquids may be increased by high RPM, high temperatures, low vapor pressures or high viscosity and may require pressurized inlet and C.A.T. to maintain adequate inlet supply. **DO NOT USE C.A.T. WITH SUCTION INLET.**
- Optimum pump performance is obtained with +20 PSI (1.4 BAR) inlet pressure and a C.A.T. for certain applications. With adequate inlet plumbing, most pumps will perform with flooded suction. Maximum inlet pressure is 60 PSI (4 BAR).
- After prolonged storage, pump should be rotated by hand and purged of air to facilitate priming. Disconnect the discharge port and allow liquid to pass through pump and measure flow.

INLET ACCESSORIES are designed to protect against overpressurization, control inlet flow, contamination or temperature and provide ease of servicing.

- A shut-off valve is recommended to facilitate maintenance.
- Installation of a C.A.T. is essential in applications with stressful conditions such as high temperatures, booster pump feed or long inlet lines. **Do not use C.A.T. with negative inlet pressure.**
- A stand pipe can be used in some applications to help maintain a positive head at the pump inlet.
- Inspect and clean inlet filters on a regular schedule to avoid flow restriction.
- A pressure transducer is necessary to accurately read inlet pressure. (**Short term, intermittent cavitation will not register on a standard gauge.**)
- All accessories should be sized to avoid restricting the inlet flow.
- All accessories should be compatible with the solution being pumped to prevent premature failure or malfunction.
- Optional inlet protection can be achieved by installing a pressure cutoff switch between the inlet filter and the pump to shut off pump when there is no positive inlet pressure.

BY-PASS TO INLET Care should be exercised when deciding the method of by-pass from control valves.

- It is recommended the by-pass be directed to a baffled reservoir tank, with at least one baffle between the by-pass line and the inlet line to the pump.
- Although not recommended, by-pass liquid may be returned to the inlet line of the pump if the system is properly designed to protect your pump. A PRESSURE REDUCING VALVE must be installed on the inlet line (**BETWEEN THE BY-PASS CONNECTION AND THE INLET TO THE PUMP**) to avoid excessive pressure to the inlet of the pump. It is also recommended that a THERMO VALVE be used in the by-pass line to monitor the temperature build-up in the by-pass loop to avoid premature seal failure.
- A low-pressure, flexible cloth braid (not metal braid) hose should be used from the by-pass connection to the inlet of the pump.
- Caution should be exercised not to undersize the by-pass hose diameter and length. Refer to Technical Bulletin 64 for additional information on the size and length of the by-pass line.
- Check the pressure in the by-pass line to avoid overpressurizing the inlet.
- The by-pass line should be connected to the pump inlet line at a gentle angle of 45° or less and no closer than 10 times the pump inlet port diameter e.g. 1-1/2" port size = 15" distance from pump inlet port.

HOSE FRICTION LOSS

Water* Flow Gal/Min	PRESSURE DROP IN PSI PER 100 FT OF HOSE WITH TYPICAL WATER FLOW RATES Hose Inside Diameters, Inches						
	1/4	5/16	3/8	1/2	5/8	3/4	1"
0.5	16	5	2				
1	54	20	7	2			
2	180	60	25	6	2		
3	380	120	50	13	4	2	
4		220	90	24	7	3	
5		320	130	34	10	4	
6			220	52	16	7	1
8			300	80	25	10	2
10			450	120	38	14	3
15			900	250	80	30	7
20			1600	400	121	50	12
25				650	200	76	19
30					250	96	24
40					410	162	42
50					600	235	62
60						370	93

*At a fixed flow rate with a given size hose, the pressure drop across a given hose length will be directly proportional. A 50 ft. hose will exhibit one-half the pressure drop of a 100 ft. hose. Above values shown are valid at all pressure levels.

WATER LINE PRESSURE LOSS PRESSURE DROP IN PSI PER 100 FEET

Water GPM	Steel Pipe—Nominal Dia.					Brass Pipe—Nominal Dia.					Copper Tubing O.D. Type L							
	1/4	3/8	1/2	3/4	1 1/4	1 1/2	1/4	3/8	1/2	3/4	1 1/4	1 1/2	1/4	3/8	1/2	5/8	3/4	7/8
1	8.5	1.9					6.0	1.6					120	13	2.9	1.0		
2	30	7.0	2.1				20	5.6	1.8				400	45	10	3.4	1.3	
3	60	14	4.5	1.1			40	11	3.6				94	20	6.7	2.6		
5	150	36	12	2.8			100	28	9.0	2.2			230	50	17	6.1	3.0	
8	330	86	28	6.7	1.9		220	62	21	5.2	1.6		500	120	40	15	6.5	
10	520	130	43	10	3.0		320	90	30	7.8	2.4		180	56	22	10		
15	270	90	21	6.2	1.6		190	62	16	5.0	1.5		120	44	20			
25	670	240	56	16	4.2	2.0	470	150	40	12	3.8	1.7	330	110	50			
40		66	17	8.0				39	11	5.0			550	200	88			
60			37	17					23	11								
80			52	29					40	19								
100			210	107	48				61	28								

RESISTANCE OF VALVES AND FITTINGS

Nominal Pipe Size Inches	Inside Diameter Inches	Equivalent Length of Standard Pipe in Feet								
		Gate Valve	Globe Valve	Angle Valve	45° Elbow	90° Elbow	180° Close Ret	Tee Thru Run	Tee Thru Branch	
1/2	0.622	0.41	18.5	9.3	0.78	1.67	3.71	0.93	3.33	
3/4	0.824	0.54	24.5	12.3	1.03	2.21	4.90	1.23	4.41	
1	1.049	0.69	31.2	15.6	1.31	2.81	6.25	1.56	5.62	
1 1/4	1.380	0.90	41.0	20.5	1.73	3.70	8.22	2.06	7.40	
1 1/2	1.610	1.05	48.0	24.0	2.15	4.31	9.59	2.40	8.63	
2	2.067	1.35	61.5	30.8	2.59	5.55	12.30	3.08	11.60	
2 1/2	2.469	1.62	73.5	36.8	3.09	6.61	14.70	3.68	13.20	
3	3.068	2.01	91.5	45.8	3.84	8.23	18.20	4.57	16.40	
4	4.026	2.64	120.0	60.0	5.03	10.80	23.90	6.00	21.60	

Arriving at a total line pressure loss, consideration should then be given to pressure loss created by valves, fittings and elevation of lines.

If a sufficient number of valves and fittings are incorporated in the system to materially affect the total line loss, add to the total line length, the equivalent length of line of each valve or fitting.

TYPICAL RESERVOIR TANK RECOMMENDED 6 TO 10 TIMES SYSTEM CAPACITY

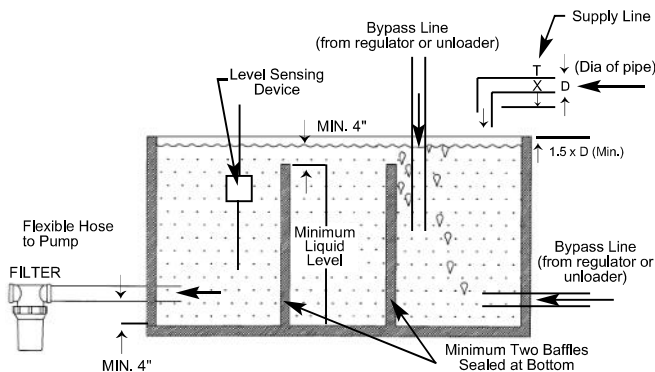

Handy Formulas to Help You

Q. How can I find the RPM needed to get specific GPM (Gallons Per Minute) I want?

$$A. \text{Desired RPM} = \text{Desired GPM} \times \frac{\text{Rated RPM}}{\text{Rated GPM}}$$

Q. I have to run my pump at a certain RPM. How do I figure the GPM I'll get?

$$A. \text{Desired GPM} = \text{Desired RPM} \times \frac{\text{Rated GPM}}{\text{Rated RPM}}$$

Q. Is there a simple way to find the approximate horsepower I'll need to run the pump?

$$A. \text{Electric Brake Horsepower Required} = \frac{\text{GPM} \times \text{PSI}}{1460} \quad (\text{Standard } 85\% \text{ Mech. Efficiency})$$

Q. What size motor pulley should I use?

$$A. \text{Pump Pulley (Outer Diameter)} \times \frac{\text{Pump RPM}}{\text{Motor/Engine RPM}} \quad (\text{Consult Engine Mfr.})$$

Q. How do I calculate the torque for my hydraulic drive system?

$$A. \text{Torque (ft. lbs.)} = 3.6 \left(\frac{\text{GPM} \times \text{PSI}}{\text{RPM}} \right)$$

Avoid Cavitation Damage

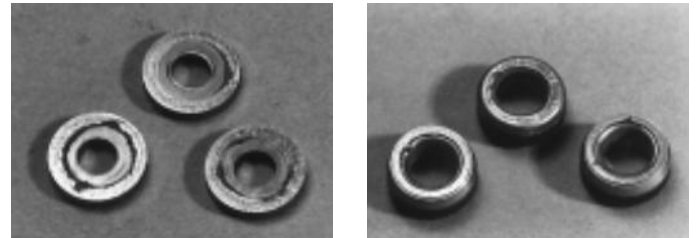

One or several of the conditions shown in the chart below may contribute to cavitation in a system resulting in premature wear, system downtime and unnecessary operating costs.

CONDITION	SOLUTION
Inadequate inlet line size	• Increase line size to the inlet port or one size larger
Water hammering/ liquid acceleration/ deceleration	• Install C.A.T. Tube • Move pump closer to liquid supply
Rigid Inlet Plumbing	• Use flexible wire reinforced hose to absorb pulsation and pressure spikes
Excessive Elbows in Inlet Plumbing	• Keep elbows to a minimum and less than 90°
Excessive liquid Temperature	• Use Thermo Valve in bypass line • Do not exceed pump temperature specifications • Substitute closed loop with baffled holding tank • Adequately size tank for frequent or high volume bypass • Pressure feed high temperature liquids • Properly ventilate cabinets and rooms
Air Leaks in Plumbing	• Check all connections • Use PTFE thread tape or pipe thread sealant
Agitation in Supply Tank	• Size tank according to pump output — Minimum 6-10 times system GPM • Baffle tank to purge air from liquid and separate inlet from discharge
High Viscosity Liquids	• Verify viscosity against pump specifications before operation • Elevate liquid temperature enough to reduce viscosity • Lower RPM of pump • Pressure feed pump • Increase inlet line size
Clogged Filters	• Perform regular maintenance or use clean filters to monitor build up • Use adequate mesh size for liquid and pump specifications

DIAGNOSIS AND MAINTENANCE

One of the most important steps in a high pressure system is to establish a regular maintenance program. This will vary slightly with each system and is determined by various elements such as the duty cycle, the liquid being pumped, the actual specifications vs rated specifications of the pump, the ambient conditions, the inlet conditions and the accessories in the system. A careful review of the necessary inlet conditions and protection devices required before the system is installed will eliminate many potential problems.

CAT PUMPS are very easy pumps to service and require far less frequent service than most pumps. Typically, only common tools are required, making in-field service convenient, however, there are a few custom tools, special to certain models, that do simplify the process. This service manual is designed to assist you with the disassembly and reassembly of your pump. The following guide will assist in determining the cause and remedy to various operating conditions. You can also review our **FAQ** or **SERVICE** sections on our **WEB SITE** for more facts or contact CAT PUMPS directly.

PROBLEM	PROBABLE CAUSE	SOLUTION	
Low pressure	<ul style="list-style-type: none"> •Worn nozzle. •Belt slippage. •Air leak in inlet plumbing. •Pressure gauge inoperative or not registering accurately. •Relief valve stuck, partially plugged or improperly adjusted. •Inlet suction strainer (filter) clogged or improperly sized. •Abrasives in pumped liquid. •Leaky discharge hose. •Inadequate liquid supply. •Severe cavitation. •Worn seals. •Worn or dirty inlet/discharge valves. 	<ul style="list-style-type: none"> •Replace with properly sized nozzle. •Tighten belt(s) or install new belt(s). •Tighten fittings and hoses. Use PTFE liquid or tape. •Check with new gauge. Replace worn or damaged gauge. •Clean/adjust relief valve. Replace worn seats/valves and o-rings. •Clean filter. Use adequate size filter. Check more frequently. •Install proper filter. •Replace discharge hose with proper rating for system. •Pressurize inlet and install C.A.T. •Check inlet conditions. •Install new seal kit. Increase frequency of service. •Clean inlet/discharge valves or install new valve kit. 	
Pulsation	<ul style="list-style-type: none"> •Faulty Pulsation Dampener. •Foreign material trapped in inlet/discharge valves. 	<ul style="list-style-type: none"> •Check precharge. If low, recharge, or install a new dampener. •Clean inlet/discharge valves or install new valve kit. 	
Water leak	<ul style="list-style-type: none"> •Under the manifold •Into the crankcase 	<ul style="list-style-type: none"> •Worn V-Packings, Hi-Pressure or Lo-Pressure Seals. •Worn adapter o-rings. •Humid air condensing into water inside the crankcase. •Excessive wear to seals and V-Packings. 	<ul style="list-style-type: none"> •Install new seal kit. Increase frequency of service. •Install new o-rings. •Install oil cap protector. Change oil every 3 months or 500 hours. •Install new seal kit. Increase frequency of service.
Knocking noise	<ul style="list-style-type: none"> •Inlet supply •Bearing •Pulley 	<ul style="list-style-type: none"> •Inadequate inlet liquid supply. •Broken or worn bearing. •Loose pulley on crankshaft 	<ul style="list-style-type: none"> •Check liquid supply. Increase line size, pressurize or install C.A.T. •Replace bearing. •Check key and tighten set screw.
Oil leak	<ul style="list-style-type: none"> •Crankcase oil seals. •Crankshaft oil seals and o-rings. •Drain plug •Bubble gauge •Rear cover •Filler cap 	<ul style="list-style-type: none"> •Worn crankcase oil seals. •Worn crankshaft oil seals or o-rings on bearing cover. •Loose drain plug or worn drain plug o-ring. •Loose bubble gauge or worn bubble gauge gasket. •Loose rear cover or worn rear cover o-ring. •Loose filler cap or excessive oil in crankcase. 	<ul style="list-style-type: none"> •Replace crankcase oil seals. •Remove bearing cover and replace o-rings and/or oil seals. •Tighten drain plug or replace o-ring. •Tighten bubble gauge or replace gasket. •Tighten rear cover or replace o-ring. •Tighten filler cap. Fill crankcase to specified capacity.
Pump runs extremely rough	<ul style="list-style-type: none"> •Inlet conditions •Pump valves •Pump seals 	<ul style="list-style-type: none"> •Restricted inlet or air entering the inlet plumbing •Stuck inlet/discharge valves. •Leaking V-Packings, Hi-Pressure or Lo-Pressure seals. 	<ul style="list-style-type: none"> •Correct inlet size plumbing. Check for air tight seal. •Clean out foreign material or install new valve kit. •Install new seal kit. Increase frequency of service.
Premature seal failure	<ul style="list-style-type: none"> •Scored plungers. •Over pressure to inlet manifold. •Abrasive material in the liquid being pumped. •Excessive pressure and/or temperature of pumped liquid. •Running pump dry. •Starving pump of adequate liquid. •Eroded manifold. 	<ul style="list-style-type: none"> •Replace plungers. •Reduce inlet pressure per specifications. •Install proper filtration at pump inlet and clean regularly. •Check pressure and inlet liquid temperature. •DO NOT RUN PUMP WITHOUT LIQUID. •Increase hose one size larger than inlet port size. Pressurize and install C.A.T. •Replace manifold. Check liquid compatibility. 	

APPENDIX J PULSATION DAMPENER



Prrrrr-O-Lator Pulsation Dampeners



FEATURES

- Nitrogen precharged to eliminate moisture and bladder deterioration.
- Broader bladder design provides greater pulsation reduction for smoother performance and longer system component life.
- Optional 316 Stainless Steel and FPM construction for critical applications.
- New sealed style operates over full range of system pressures without precharge adjustment.

Sealed Models

6026, 6028

SPECIFICATIONS

	U.S. Measure	Metric Measure
Maximum Flow	15 GPM	(57 L/M)
Working Pressure Range (6026).....	300-600 PSI*	(20-41 BAR)
Working Pressure Range (6028).....	600-1000 PSI*	(41-70 BAR)
Precharge (6026 Sealed)	250 PSI	(17 BAR)
Precharge (6028 Sealed)	450 PSI	(32 BAR)
Operating Temperature Range.....	+5 to 180°F	(-20 to 82°C)
Volume	10 cu. in.	(0.16 L)
Safety Factor	4/1	(4/1)
Bladder Construction	NBR	(NBR)
Port Size	1/2" NPTM	(1/2" NPTM)
Diameter.....	2.93"	(74.5 mm)
Length	4.67"	(118.7 mm)
Weight.....	1.81 lbs.	(0.84 kg)

*Optimum pulsation dampening at stated PSI. If full dampening is not critical, performance is acceptable up to 3000 PSI system pressure.

Stainless Steel Lower Body

Rechargeable Models 6029, 6030

SPECIFICATIONS

	U.S. Measure	Metric Measure
Maximum Flow	15 GPM	(57 L/M)
Working Pressure Range	100-3000 PSI	(7-210 BAR)
Precharge (Rechargeable)	450 PSI	(32 BAR)
Operating Temperature Range.....	+5 to 180°F	(-20 to 82°C)
Volume	10 cu. in.	(0.16 L)
Safety Factor	4/1	(4/1)
Bladder Construction (6029).....	NBR	(NBR)
Bladder Construction (6030).....	FPM	(FPM)
Port Size	1/2" NPTM	(1/2" NPTM)
Diameter.....	2.93"	(74.5 mm)
Length	5.51"	(140 mm)
Weight.....	2.18 lbs.	(1.02 kg)

For change in precharge add .800 to model number.

All Stainless Steel Rechargeable Model

6031

SPECIFICATIONS

	U.S. Measure	Metric Measure
Maximum Flow	15 GPM	(57 L/M)
Working Pressure Range	100-2400 PSI	(7-168 BAR)
Precharge (Rechargeable)	450 PSI	(32 BAR)
Operating Temperature Range.....	+5 to 180°F	(-20 to 82°C)
Volume	10 cu. in.	(0.16 L)
Safety Factor	4/1	(4/1)
Bladder Construction	NBR	(NBR)
Port Size	1/2" NPTM	(1/2" NPTM)
Diameter.....	2.93"	(74.5 mm)
Length	5.51"	(140 mm)
Weight.....	2.18 lbs.	(1.02 kg)

For change in precharge add .800 to model number.

"Customer confidence is our greatest asset"

INSTALLATION INSTRUCTIONS

SELECTION: The Prrrrr-O-Lator should be selected to match the flow and pressure requirements of the system and satisfy the liquid compatibility.

INSTALLATION: The Prrrrr-O-Lator should be mounted directly onto the pump discharge manifold for optimum pulsation dampening and to avoid system vibration damage.

OPERATION: The Prrrrr-O-Lator should be precharged with **dry Nitrogen only**.

⚠ WARNING

Never use oxygen or air. This could cause an explosion.

The standard Prrrrr-O-Lator is precharged to 450 PSI, however, it may be adjusted to offer a more precise control of pulsation in critical applications such as reverse osmosis.

“Sealed” Prrrrr-O-Lators are preset at 250 or 450 PSI and are designed to operate over the full range of system pressures from 600 to 1000 PSI.

At a standard temperature of 70°F, optimum accumulator performance is obtained when the precharge is calibrated at 50% of the system operating pressure.

NOTE

When operating at the lower temperatures, precharge should be 15% higher or 65% of system pressure. When operating at higher temperatures, precharge should be 15% lower or 35% of system pressure.

This precharge should be checked every 12 months for normal operation and more frequently for continuous-duty operation.

NOTE

Up to 50 PSI precharge pressure can be lost during the checking of your precharge.

CAUTION

A gas regulator must be mounted between the nitrogen tank and the hose connection from the Filling and Gauging Assembly to enable you to regulate the precharge and to prevent excessive pressure being transmitted directly to the accumulator. **OVER PRESSURIZATION WILL VOID THE WARRANTY.**

DIMENSIONAL

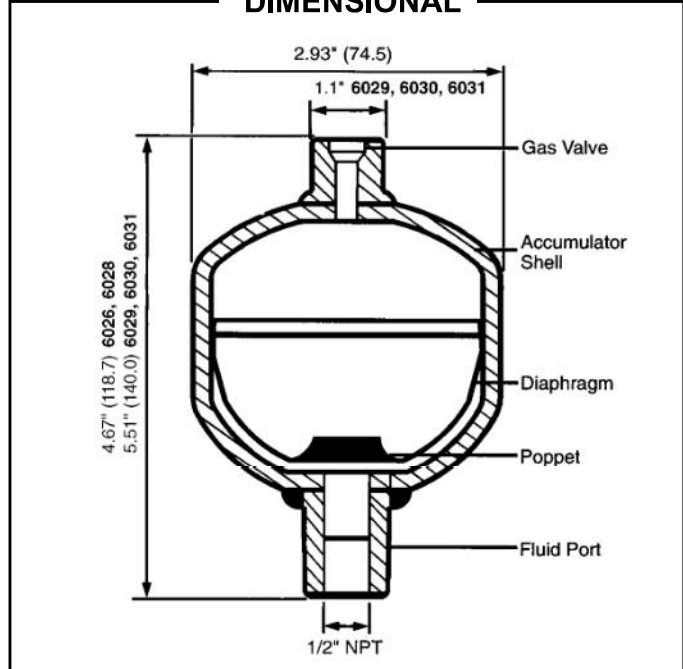

FILLING AND GAUGING INSTRUCTIONS

The following are the steps in both checking the precharge of the accumulator and recharging if there should be a loss of pressure or a need for adjustment.

1. Before checking your precharge, **system pressure should be at zero. TURN SYSTEM OFF.**
2. **SLIGHTLY** loosen the sealed valve at the top of the accumulator using a 6mm long handled allen wrench. Thread on the Filling and Gauging Assembly hand tight.
3. Be certain the **SIDE BLEED VALVE** on the gauging assembly is **CLOSED**.
4. Slowly open the **LARGE “T” VALVE** at the top of the gauging assembly until completely open. The gauge on the assembly will read the precharge on the accumulator.
5. Completely back off (**CLOSE**) the valve on the gas regulator, open the nitrogen tank valve and read the nitrogen tank pressure on the first gauge.
6. If the reading on the gauge assembly is 50% of the system pressure, close the top “T” valve and proceed to step 9.
7. If the precharge is too high, keep the top “T” valve open and slowly open the small “T” valve on the side of the gauging assembly to bleed of pressure.
8. If the pressure is less than 50% of the system pressure, slowly

open the gas regulator valve until the desired precharge is reached on the second gauge.

9. When the gauge reads the required precharge, close the “T” valve on the top of the gauging assembly to lock the precharge in the accumulator.
10. Back off (**CLOSE**) the gas regulator.
11. Proceed with opening the small side “T” valve on the gauging assembly to relieve (bleed-off) pressure in the assembly and on the second gauge on the gas regulator.
12. Close the side “T” valve on the gauging assembly and remove the assembly from the accumulator.
13. Tighten the accumulator sealed valve and resume operation.

- 30940 Complete Filling and Gauging Assembly (Optional)
- 30941 Allen Wrench (Included in Assembly)
- 6099 Pressure Gauge (Included in Assembly)



Products described hereon are covered by one or more of the following U.S. patents 3558244, 3652188, 3809508, 3920356, 3930756 and 5035580

World Headquarters

CAT PUMPS

1681 - 94th Lane N.E. Minneapolis, MN 55449-4324

Phone (763) 780-5440 — FAX (763) 780-2958

e-mail: sales@catpumps.com

www.catpumps.com

International Inquiries

FAX (763) 785-4329

e-mail: intl@catpumps.com



The Pumps with Nine Lives

CAT PUMPS (U.K.) LTD.

1 Fleet Business Park, Sandy Lane, Church Crookham, Fleet

Hampshire GU52 8BF, England

Phone Fleet 44 1252-622031 — Fax 44 1252-626655

e-mail: sales@catpumps.co.uk

N.V. CAT PUMPS INTERNATIONAL S.A.

Heiveldekens 6A, 2550 Kontich, Belgium

Phone 32-3-450.71.50 — Fax 32-3-450.71.51

e-mail: cpi@catpumps.be www.catpumps.be

CAT PUMPS DEUTSCHLAND GmbH

Buchwiese 2, D-65510 Idstein, Germany

Phone 49 6126-9303 0 — Fax 49 6126-9303 33

e-mail: catpumps@t-online.de www.catpumps.de

APPENDIX K PRESSURE REGULATOR



7021-7033

7001-7003

7011-7014

FEATURES

- Lightweight flow-through design for easy installation.
- Unique high velocity design assures consistent pressure for multiple pump or shut-off gun installations.
- All metal wear parts are stainless steel; all elastomers are FPM for durability.
- Adjusting nut allows easy calibrated pressure adjustment.
- Multiple regulators can be installed in parallel to handle larger volumes.
- No external moving parts or springs.

⚠ WARNING

All systems require both a primary pressure regulating device (i.e., regulator, unloader) and a secondary pressure safety relief device (i.e., pop-off valve, safety valve). Failure to install such relief devices could result in personal injury or damage to the pump or to system components. CAT PUMPS does not assume any liability or responsibility for the operation of a customer's high pressure system.

Pressure Regulator

Standard Models

7001-7033

Stainless Steel Models

7001.100-7033.100

SPECIFICATIONS

	U.S. Measure	Metric Measure
MODELS 7001, 7002, 7003 AND .100		
Flow Range	0.5-5.0 GPM	(1.9-19 L/M)
Pressure Range (7001)	100-1000 PSI	(7-70 BAR)
(7002)	500-2000 PSI	(35-140 BAR)
(7003)	1500-3000 PSI	(105-210 BAR)
Max. Temperature	180°F	(82°C)
Inlet/Outlet Port	3/8" NPTF	(3/8" NPTF)
By-Pass Port	1/2" NPTF	(1/2" NPTF)
Weight	2.25 lbs.	(1.02 kg)
Dimensions	6.25 x 1.5"	(159 x 38 mm)

MODELS 7011, 7012, 7013, 7014 AND .100

Flow Range	1.0-10.0 GPM	(3.8-38 L/M)
Pressure Range (7011)	100-1000 PSI	(7-70 BAR)
(7012)	500-2000 PSI	(35-140 BAR)
(7013)	1500-3000 PSI	(105-210 BAR)
(7014)	2000-4000 PSI	(140-275 BAR)
Max. Temperature	180°F	(82°C)
Inlet/Outlet Port	1/2" NPTF	(1/2" NPTF)
By-Pass Port	3/4" NPTF	(3/4" NPTF)
Weight	3.75 lbs.	(1.70 kg)
Dimensions	7.5 x 1.88"	(191 x 48 mm)

MODELS 7021, 7022, 7023, 7024 AND .100

Flow Range	2.5-25.0 GPM	(9.5-95 L/M)
Pressure Range (7021)	100-1000 PSI	(7-70 BAR)
(7022)	500-2000 PSI	(35-140 BAR)
(7023)	1500-3000 PSI	(105-210 BAR)
(7024)	2000-4000 PSI	(140-275 BAR)
Max. Temperature	180°F	(82°C)
Inlet/Outlet Port	3/4" NPTF	(3/4" NPTF)
By-Pass Port	1" NPTF	(1" NPTF)
Weight	5.0 lbs.	(2.40 kg)
Dimensions	8.5 x 2.25"	(216 x 57 mm)

MODELS 7031*, 7032, 7033 AND .100

Flow Range	3.5-35 GPM	(13.2-133 L/M)
Pressure Range (7031)	250-1000 PSI	(18-70 BAR)
(7032)	1000-2000 PSI	(70-140 BAR)
(7033)	1500-3000 PSI	(105-210 BAR)
Max. Temperature	180°F	(82°C)
Inlet/Outlet Port	3/4" NPTF	(3/4" NPTF)
By-Pass Port	1" NPTF	(1" NPTF)
Weight	5.5 lbs.	(2.50 kg)
Dimensions	8.5 x 2.25"	(216 x 57 mm)

* Model 7031 replaces model 7028.

"Customer confidence is our greatest asset"

SELECTION

This pressure regulator is designed for systems with single or multiple pumps, solenoid (gate) valves, nozzles, and standard or “weep” guns.

Note: For multiple pump systems, it is best to use a pressure regulator not a pressure sensitive regulating unloader.

This regulator should meet both the desired system flow (combined nozzle flow rate requirement) and the desired system pressure.

Note: Operation below the minimum flow of the regulator causes the regulator to cycle or chatter. Operation above the maximum flows of the regulator causes premature regulator wear, regulator cycling and prevents attaining desired system pressure.

INSTALLATION

This regulator operates properly when mounted in any direction; however, it is preferred to keep the plumbing to a minimum and the pressure adjusting nut easily accessible. The best mounting location is directly on the pump discharge manifold head. Flexible, high pressure hose (minimum single wire braid) should be at least the size of the regulator ports when plumbing to and from the regulator.

Since this is a flow through design regulator, the inlet and discharge connections are interchangeable and are located on the sides. An arrow on the label indicates liquid flow in either direction. Port size varies with each size of regulator (see specifications). Plumb into one side for inlet flow from pump and plumb opposite side to the discharge line with spray guns, solenoid (gate) valves or nozzles.

The by-pass connection of this regulator is located on the bottom. An arrow on the label indicates the direction of flow. Port size varies with each size of regulator (see specifications). By-pass liquid is directed out this port and can be routed to a reservoir (preferred method), or to a drain or back to the pump inlet.

OPERATION

This pressure regulator maintains established system pressure in the discharge line and at the pump head when the trigger gun is closed or solenoid (gate) valve is closed or the nozzle is clogged, thus by-passing all unrequired flow. Squeezing the trigger gun or opening the solenoid (gate) valve allows for a quick return to established system pressure without delay.

PRESSURE ADJUSTMENT

1. Setting and adjusting the regulator pressure must be done with the system “on”.
2. Start the system with regulator backed off to the lowest pressure setting (counterclockwise direction).
3. Squeeze the trigger and read the pressure on the gauge at the pump.

Note: Do not read the pressure at the gun or nozzle.

4. If more pressure is desired, release the trigger, turn brass adjusting nut one quarter turn in clockwise direction.
5. Squeeze the trigger and read the pressure.
6. Repeat this process until desired system pressure is attained.
7. Once the desired system pressure is reached, stop turning the brass adjusting nut.

CAUTION: A minimum by-pass flow of 5% of the regulator rated flow capacity is required for proper regulator performance. If the entire output is directed through the regulator (zero by-pass) the “cushioning” feature of the by-pass liquid is eliminated and the regulator can malfunction or wear prematurely.

8. If desired system pressure cannot be reached, review TROUBLESHOOTING chart.
9. When servicing existing systems, back off adjusting nut.
10. Follow adjustment procedures as stated above.

Note: Do not adjust regulators pressure setting to compensate for a worn nozzle. Check the nozzle as part of the regular maintenance and replace if worn.

Note: A secondary pressure safety relief device (i.e. pop-off valve, safety valve) should be used along with this pressure regulator. Final adjustment for the relief valve should relieve at 200 psi above the system operating pressure.

TYPICAL REGULATOR INSTALLATION

- 1 Pressure Gauge
- 2 Relief Valve
Shown as a secondary safety relief valve
- 3 Pulsation Dampener
- 4 Pressure Regulator
- 5 Triplex Plunger Pump

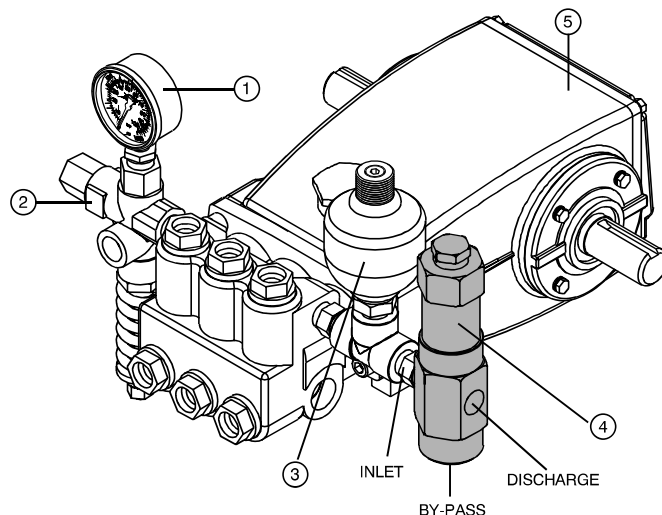

SERVICING

CAUTION: Before commencing with service, shut off drive (electric motor, gas or diesel engine) and turn off water supply to pump. Relieve all discharge line pressure by triggering gun or opening valve in discharge line.

Disassembly

1. Disconnect by-pass, discharge and inlet plumbing from regulator.
2. Remove regulator from pump.
3. Secure lower body of regulator in a vise with brass adjusting nut facing up.
4. Remove upper body by unthreading from lower body.
5. Grasp top of piston stem and separate from conical piston.
6. Remove piston stem with stack of spring washers, flat washers and anti-rotating washer and place on flat surface.
7. Remove conical piston with reverse pliers by making contact on the inside diameter of conical piston.

CAUTION: Exercise extreme caution to avoid contact and damage to outside diameter and sharp tip of conical piston.

8. Remove piston retainer from lower body of regulator.

CAUTION: Exercise extreme caution to avoid contact and damage to the inside diameter of the piston retainer.

9. Remove conical seat from lower body of regulator.

CAUTION: Exercise extreme caution to avoid contact and damage to outside diameter and the tapered surface of the seat.

Note: With the regulator completely disassembled, inspect lower body sealing areas where the conical seat and piston retainer makes contact for grooves, pitting and wear. If damage is found, replace with new lower body or complete new regulator. If not, proceed with reassembly.

Reassembly

Note: Conical piston and seat should be changed as a matched set when upgrading from the old tapered piston and seat. See Tech Bulletin 097.

Note: Spring washers and flat washers should be changed as a spring set. See Tech Bulletin 102.

1. Place lower regulator body with by-pass port facing down into a vise.
2. Lubricate and install o-ring onto outside diameter of conical seat. Press conical seat down into lower regulator body with small hole facing up.
3. Lubricate and install o-ring onto piston retainer. Press piston retainer with raised surface facing up.
4. Lubricate and install back-up-ring, then o-ring onto outside diameter of conical piston. Press conical piston with sharp point down into piston retainer.
5. Replace piston stem with stack of spring washers and flat washers into hole of conical piston.
6. Place anti-rotating washer on top of spring set. Align tabs on washer with slots on the upper body.

Note: The number of flat washers varies with each spring set. Place the first flat washer between the anti-rotating washer and spring stack. Place second washer (if required) between spring stack and retaining ring. Place all remaining washers with first washer.

7. Thread upper body into lower body.
8. Re-install regulator onto pump.
9. Reconnect by-pass, discharge and inlet plumbing to regulator.
10. Proceed to PRESSURE ADJUSTMENT.

TROUBLESHOOTING

Cycling / Chattering	<ul style="list-style-type: none"> ● Too little flow for valve specifications. ● Air in system, poor connections. ● Inlet seals in pump worn. ● O-ring in gun worn.
System will not build up to pressure	<ul style="list-style-type: none"> ● Nozzle worn. ● Improper nozzle size for system specs. ● Foreign material trapped in seat.
Pressure drop	<ul style="list-style-type: none"> ● Nozzles worn. ● Piston and seat in regulator worn. ● Air in system, poor connections. ● Insufficient flow to pump. ● Filter clogged. Check and clean regularly. ● Fatigued or broken spring washers.
Pressure spikes while in by-pass	<ul style="list-style-type: none"> ● Minimum by-pass of 5% not present. ● Excessive pressure adjustment made for worn nozzle. REPLACE NOZZLE. Reset system pressure.
Leakage from regulator vent hole or top slots	<ul style="list-style-type: none"> ● O-ring around piston worn. Service with O-ring Kit. ● Piston Retainer scored. Service with O-ring kit. ● Fatigued or broken spring washers.

Approximate Pressure Reading at Gauge	Gauge Between Pump/Regulator	Gauge Between Regulator/Gun-Nozz-Valve
System in operation (gun open)	system pressure	system pressure
System in by-pass (gun closed)	200-300 PSI above system pressure	200-300 PSI above system pressure

90 DAY WARRANTY

Refer to complete CAT PUMPS Warranty for further information.

EXPLODED VIEW

(Models 7001, 7002, 7003 shown)

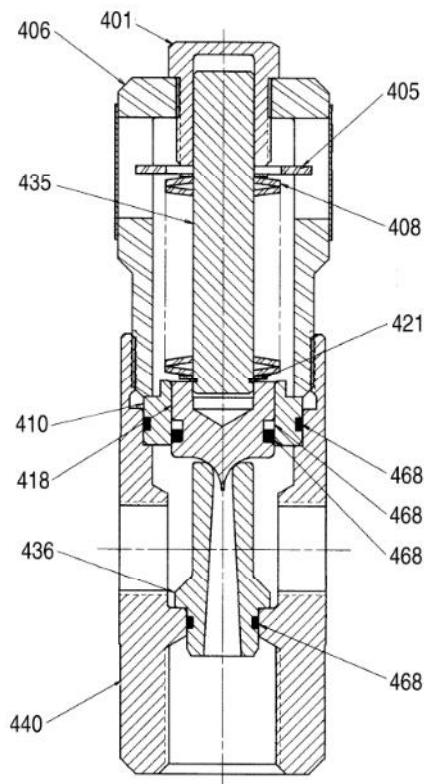

CUTAWAY

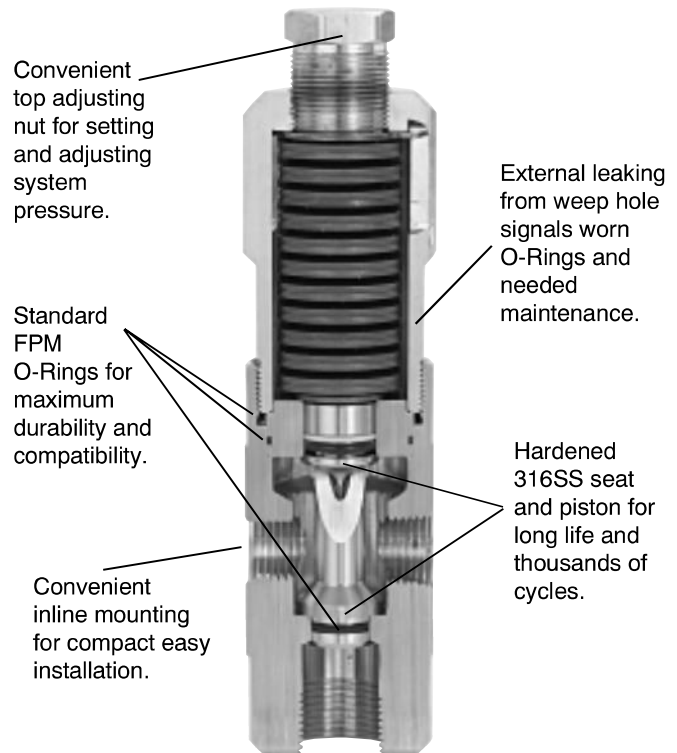

PARTS LIST

Item	Description	MATL	7001	7002	7003	7011	7012	7013	7014	7021	7022	7023	7024	7031	7032	7033
401	Nut, Adjusting	BB	30758	30758	30758	30759	30759	30759	30759	30760	30760	30760	30760	30760	30760	30760
405	Washer, Anti-Rot	STL	34491	34491	34491	34492	34492	34492	34492	34493	34493	34493	34493	34493	34493	34493
406	Body, Upper		—	—	—	—	—	—	—	—	—	—	—	—	—	—
408	Spring Set	STL	76201	76202	76202	76211	76212	76213	76214	76221	76222	76223	76224	76221	76222	76223
410	Retainer, Piston	SSS	30873	30873	30874	30875	30875	30876	30876	30877	30877	30878	30878	30877	30877	30878
	<i>Retainer, Piston (.100 Option)</i>	SS	<i>33885</i>	<i>33885</i>	<i>33886</i>	<i>31635</i>	<i>31635</i>	<i>31666</i>	<i>31666</i>	<i>33877</i>	<i>33877</i>	<i>31878</i>	<i>31878</i>	<i>33877</i>	<i>33877</i>	<i>30878</i>
418	Piston, Conical	SSB	31733	31733	31734	31738	31738	31739	31739	31743	31743	31744	31744	—	—	—
	Piston, Conical	SSSS	—	—	—	—	—	—	—	—	—	—	—	31749	31749	31750
421	Ring, Retainer	STL	30585	30585	30885	30886	30886	30886	30886	30887	30887	30887	30887	30887	30887	30887
435	Stem, Piston	STL	30588	30588	30888	30889	30889	30889	30889	30892	30892	30892	30892	30892	30892	30892
436	Seat, Conical	SSB	31732	31732	31732	31736	31736	31736	31736	31742	31742	31742	31742	—	—	—
	Seat, Conical	SSSS	—	—	—	—	—	—	—	—	—	—	—	31748	31748	31748
440	Body, Lower	STNP	—	—	—	—	—	—	—	—	—	—	—	—	—	—
	<i>Body, Lower (.100 Option)</i>	SS	—	—	—	—	—	—	—	—	—	—	—	—	—	—
468	Kit, O-Ring, Hex Body Style	FPM	30771	30771	30775	30777	30777	30781	30781	30783	30783	30787	30787	30783	30783	30787
—	<i>Kit, O-Ring, Round Body Style</i>	FPM	30770	30772	30774	30776	30778	30780	—	30782	30784	30786	—	—	—	—

It is recommended to replace spring washers and flat washers as a set.

Italics are optional items. See Tech Bulletins 022, 044,097 and 102 for additional information.

Material Codes (Not Part of Part Number):

BB=Brass FPM=Fluorocarbon SS=316SS SSB=316SS Condition B SSS=416SS SSSS=440SS STNP=Steel/Nickel Plated STL=Steel

Contact CAT PUMPS for optional NBR or EPDM O-Ring Kits.

Products described hereon are covered by one or more of the following U.S. patents 3558244, 3652188, 3809508, 3920356, 3930756 and 5035580

World Headquarters

CAT PUMPS

1681 - 94th Lane N.E. Minneapolis, MN 55449-4324

Phone (763) 780-5440 — FAX (763) 780-2958

e-mail: techsupport@catpumps.com

www.catpumps.com

International Inquiries

FAX (763) 785-4329

e-mail: intl@catpumps.com



The Pumps with Nine Lives

CAT PUMPS (U.K.) LTD.

1 Fleet Business Park, Sandy Lane, Church Crookham

FLEET, Hampshire, GU52 8BF, England

Phone Fleet 44 1252-622031 — Fax 44 1252-626655

e-mail: sales@catpumps.co.uk

N.V. CAT PUMPS INTERNATIONAL S.A.

Heveldekens 6A, B-2550 Kontich, Belgium

Phone 32-3-450.71.50 — Fax 32-3-450.71.51

e-mail: cpi@catpumps.be www.catpumps.be

CAT PUMPS DEUTSCHLAND GmbH

Buchwiese 2, D-65510 Idstein, Germany

Phone 49 6126-9303 0 — Fax 49 6126-9303 33

e-mail: catpumps@t-online.de www.catpumps.de

APPENDIX L FLOAT SWITCH



Model L6 FLOTECT® Float Switch

Specifications - Installation and Operating Instructions

Explosion-Proof; UL and CSA Listed -
Class I, Groups *A, B, C, & D
Class II, Groups E, F & G
Directive 94/9/EC (ATEX) Compliant for
II 2 G EEx d IIC T6 Process Temp ≤75°C
 *(Group A, stainless steel body only)



SPECIFICATIONS

Service: Liquids compatible with wetted materials.

Wetted Materials:

Float: Solid polypropylene or 304 SS.

Lower Body: Brass or 303 SS.

Magnet: Ceramic.

External Float Chamber (Tee): Matches lower body choice of brass or 303 SS.

Other: Lever Arm, Spring, Pin, etc.: 301 SS.

Temperature Limit: -4 to 220°F (-20 to 105°C) Standard, MT high temperature option 400°F (205°C) (MT not UL, CSA or ATEX). ATEX compliant AT option ambient temperature -4 to 167°F (-20 to 75°C) process temperature: -4 to 220°F (-20 to 105°C).

Pressure Limits: See next page.

Enclosure Rating: Weatherproof and Explosion-proof. Listed with UL and CSA for Class I, Groups A, B, C and D; Class II, Groups E, F, and G. (Group A on stainless steel body models only). II 2 G EEx d IIC T6 Process Temp ≤75°C.

EC-Type Certificate No.: KEMA 04ATEX2128

Switch Type: SPDT snap switch standard, DPDT snap switch optional.

Electrical Rating: UL models: 5A @ 125/250 VAC (V-). CSA and ATEX models: 5A @ 125/250 VAC (V-); 5A res., 3A ind. @ 30 VDC (V=). MV option: .1A @ 125 VAC (V-). MT option: 5A @ 125/250 VAC (V-). [MT option not UL, CSA or ATEX].

Electrical Connections: UL models: 18 AWG, 18" (460 mm) long. ATEX/CSA models: terminal block.

Upper Body: Brass or 303 SS.

Conduit Connection: 3/4" male NPT standard, 3/4" female NPT on junction box models.

Process Connection: 1" male NPT on models without external float chamber, 1" female NPT on models with external float chamber.

Mounting Orientation: Horizontal with index arrow pointing down.

Weight: Approximately 1 lb (.5 kg) without external float chamber, 1.75 lb (.8 kg) with external float chamber.

Specific Gravity: See next page.

Example	L6	EP	B	B	S	3	B	MT	L6EPB-B-S-3-B-MT level switch; brass upper housing, brass lower housing, brass tee with Polypropylene spherical float, SPDT snap switch, and high temperature option
Series	L6								Series L6 level switch
Construction		EP							Explosion proof and weatherproof
Upper Body Material			B						Brass 303 Stainless Steel
Lower Body Material				B					Brass 303 Stainless Steel
Circuit (Switch) Type					S				SPDT DPDT
Line Size						3 4 5 6			1" NPT 1-1/4" NPT (No tee models only) 1-1/2" NPT (No tee models only) 2" NPT
Tee and Float Options							O A B C H L S		No Tee, Solid Polypropylene Spherical Float* No Tee, 304 SS Cylindrical Float Brass Tee, Solid Polypropylene Spherical Float* No Tee, 304 SS Spherical Float Brass Tee, 304 SS Spherical Float 303 SS Tee, 304 SS Spherical Float 303 SS Tee, Solid Polypropylene Spherical Float*
Switch Options								MV MT	Gold Contacts on snap switch for dry circuits (see specifications for ratings) High Temperature switch rated 400°F (205°C) (see specifications for ratings)*
Options								AT CSA GL ID JCT TBC TOP	ATEX approved construction (with JCT option standard) CSA approved construction (with JCT option standard)* Ground Lead* Customer Information on standard nameplate Weatherproof and explosion-proof junction box* Terminal Block Connector* Top Mounted (No tee models only)*

* Options that do not have ATEX

Attention: Units without the "AT" suffix are not Directive 94/9/EC (ATEX) compliant. These units are not intended for use in potentially hazardous atmospheres in the EU. These units may be CE marked for other Directives of the EU.

W.E. ANDERSON DIV., DWYER INSTRUMENTS, INC.
 P.O. BOX 358 • MICHIGAN CITY, INDIANA 46361 U.S.A.

Phone: 219/879-8000
Fax: 219/872-9057

www.dwyer-inst.com
e-mail: info@dwyer-inst.com

MAXIMUM PRESSURE CHART

Model Number	Float	Minimum Sp. Gr.	Pressure Rating psig (bar)
L6EPB-B-S-3-A	Cylindrical SS	0.5	200 (13.8)
L6EPB-B-S-3-B	Polypropylene	0.9	250 (17.2)
L6EPB-B-S-3-C	Round SS	0.7	350 (24.1)
L6EPB-B-S-3-H	Round SS	0.7	250 (17.2)
L6EPB-B-S-3-O	Polypropylene	0.9	1000 (69.0)
L6EPB-S-S-3-A	Cylindrical SS	0.5	200 (13.8)
L6EPB-S-S-3-C	Round SS	0.7	350 (24.1)
L6EPB-S-S-3-L	Round SS	0.7	350 (24.1)
L6EPB-S-S-3-O	Polypropylene	0.9	2000 (138)
L6EPB-S-S-3-S	Polypropylene	0.9	2000 (138)

WETTED MATERIALS CHART

Model	Brass	Bronze	Ceramic	Polypropylene	301SS	303SS	304SS
B-S-3-A	X		X		X		X
B-S-3-B	X	X	X	X	X		
B-S-3-C	X		X		X		X
B-S-3-H	X	X	X		X		X
B-S-3-O	X	X	X	X	X		
S-S-3-A			X	X	X		X
S-S-3-C			X		X	X	X
S-S-3-L			X		X	X	X
S-S-3-O			X	X	X	X	
S-S-3-S			X	X	X	X	

INSTALLATION

Unpack switch and remove any packing material found inside lower housing or float chamber.

Switch must be installed with body in a horizontal plane and arrow on side pointing down.

If switch has an external float chamber (tee), connect it to vertical sections of 1" NPT pipe installed outside vessel walls at appropriate levels. If unit has no external float chamber, it must be mounted in a 1" NPT half coupling welded to the vessel wall. The coupling must extend through the wall.

Inspect and clean wetted parts at regular intervals.

ELECTRICAL CONNECTIONS

Connect wire leads in accordance with local electrical codes and switch action required. N.O. contacts will close and N.C. contacts will open when liquid level causes float to rise. They will return to "normal" condition on decreasing liquid level. Black = common, Blue = N.O. and Red = N.C.

For units supplied with both internal and external grounds the ground screw inside the housing must be used to ground the control. The external ground screw is for supplementary bonding when allowed or required by local code. Some CSA listed models are furnished with a separate green ground wire. Such units must be equipped with a junction box, not supplied but available on special order.

EC-Type Certificate Installation Instructions:

Cable Connection

The cable entry device shall be certified in type of explosion protection flameproof enclosure "d", suitable for conditions of use and correctly installed. For ambient temperatures over 70°C, cable and cable glands suitable for at least 90°C shall be used.

Conduit Connection

An EEx d certified sealing device such as a conduit seal with setting compound shall be provided immediately to the entrance of the valve housing. For ambient temperatures over 70°C, the wiring and setting compound in the conduit seal shall be suitable for at least 90°C.

Note: ATEX units only: The temperature class is determined by the maximum ambient and or process temperature. Units are intended to be used in ambient of $-20^{\circ}\text{C} \leq T_{amb} \leq 75^{\circ}\text{C}$. Units may be used in process temperatures up to 105°C providing the enclosure and switch body temperatures do not exceed 75°C. The standard Temperature Class is T6 Process Temp $\leq 75^{\circ}\text{C}$.

All wiring, conduit and enclosures must meet applicable codes for hazardous areas. Conduits and enclosures must be properly sealed. For outdoor or other locations where temperatures vary widely, precautions should be taken to prevent condensation inside switch or enclosure. Electrical components must be kept dry at all times.

CAUTION: To prevent ignition of hazardous atmospheres, disconnect the device from the supply circuit before opening. Keep assembly tightly closed when in use.

MAINTENANCE

Inspect and clean wetted parts at regular intervals. The cover should be in place at all times to protect, the internal components from dirt, dust and weather and to maintain hazardous location ratings. Disconnect device from the supply circuit before opening to prevent ignition of hazardous atmosphere.

FLOTECT® MODEL L-6 FLOAT SWITCH — DIMENSION DRAWINGS

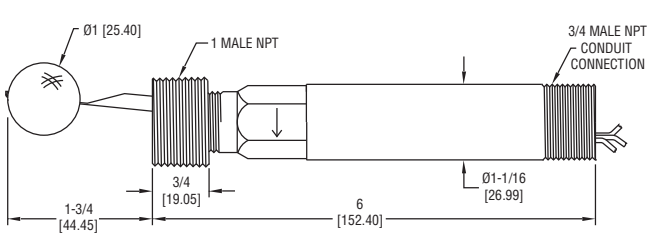

Polypropylene Float

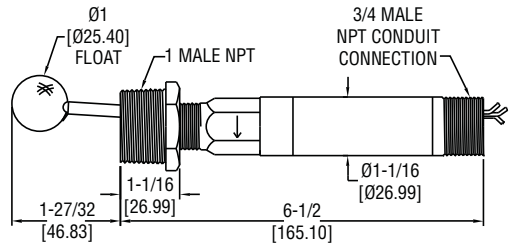

Round Stainless Steel Float

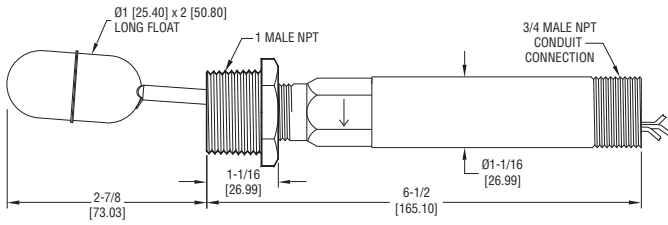

Cylindrical Stainless Steel Float

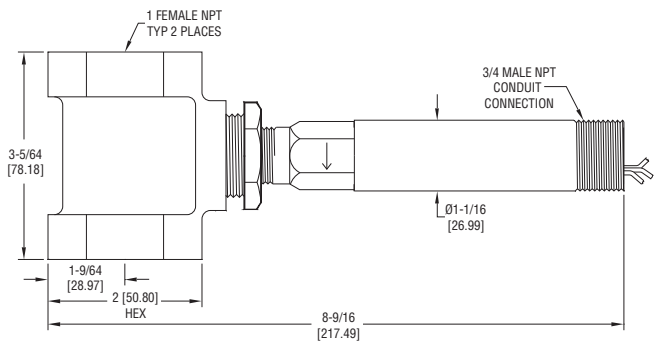

With External Chamber (Tee)

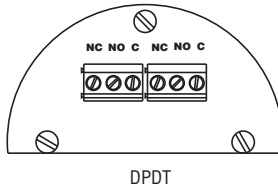
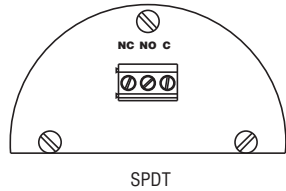

Terminal Connections CSA, ATEX Enclosures

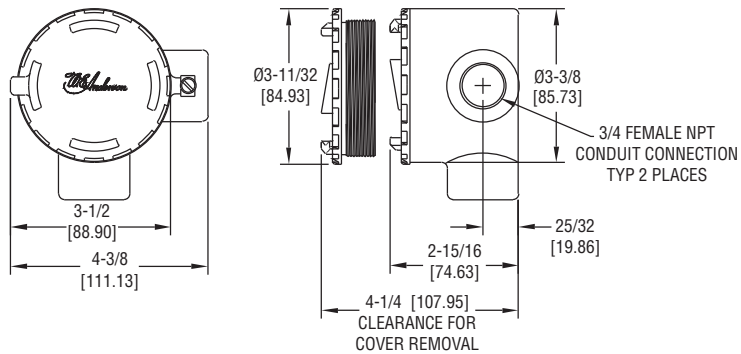

CSA, ATEX Conduit Enclosure

Limited Warranty: The Seller warrants all Dwyer instruments and equipment to be free from defects in workmanship or material under normal use and service for a period of one year from date of shipment. Liability under this warranty is limited to repair or replacement F.O.B. factory of any parts which prove to be defective within that time or repayment of the purchase price at the Seller's option provided the instruments have been returned, transportation prepaid, within one year from the date of purchase. All technical advice, recommendations and services are based on technical data and information which the Seller believes to be reliable and are intended for use by persons having skill and knowledge of the business, at their own discretion. In no case is Seller liable beyond replacement of equipment F.O.B. factory or the full purchase price. This warranty does not apply if the maximum ratings label is removed or if the instrument or equipment is abused, altered, used at ratings above the maximum specified, or otherwise misused in any way.

THIS EXPRESS LIMITED WARRANTY IS IN LIEU OF AND EXCLUDES ALL OTHER REPRESENTATIONS MADE BY ADVERTISEMENTS OR BY AGENTS AND ALL OTHER WARRANTIES, BOTH EXPRESS AND IMPLIED. THERE ARE NO IMPLIED WARRANTIES OF MERCHANTABILITY OR OF FITNESS FOR A PARTICULAR PURPOSE FOR GOODS COVERED HEREUNDER.

Buyers Remedies: THE BUYER'S EXCLUSIVE AND SOLE REMEDY ON ACCOUNT OF OR IN RESPECT TO THE FURNISHING OF NON-CONFORMING OR DEFECTIVE MATERIAL SHALL BE TO SECURE REPLACEMENT THEREOF AS AFORESAID. THE SELLER SHALL NOT IN ANY EVENT BE LIABLE FOR THE COST OF ANY LABOR EXPENDED ON ANY SUCH MATERIAL OR FOR ANY SPECIAL, DIRECT, INDIRECT OR CONSEQUENTIAL DAMAGES TO ANYONE BY REASON OF THE FACT THAT IT SHALL HAVE BEEN NON-CONFORMING OR DEFECTIVE.